

# 3-PIECE TUBE ASSEMBLY **SAE37°FLARE**



STAINLESS STEEL  
HIGH PRESSURE 37°  
TUBE FITTINGS  
1/8" TO 2"



## MEETS SAE STANDARD J514

If necessary, see SAE Standard J514 for a complete list of dimensions. NPT Tapered Pipe Threads meet the requirements of ASME/ANSI B.1.20.1.

All 37° Flared Tube Fittings 3-Piece Tube Assembly can be used with a metric tube by using a metric 37° sleeve, instead of an inch sleeve. Each dimension table shows which metric sleeve should be used for every size.

### ASSEMBLY INSTRUCTIONS

1. Cut the tube to the proper length.
2. Slide the nut and sleeve onto the tube. (see Fig.1).
3. With a special flaring tool, form the flare to 37° dimension according to SAE STD. J533. (see Fig.2 page 125).
4. Screw the nut onto the body until finger tight.
5. From this position, tighten the nut with a wrench 1/4" turn in order to make a leakproof metal-to-metal connection.

Figure 1

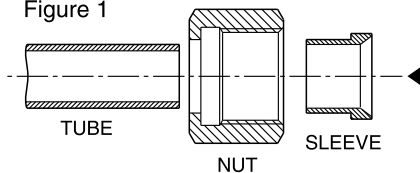

### TUBING DATA FOR 37° FLARE THREE-PIECE TUBE ASSEMBLY

In order to ensure maximum fitting reliability and performance, please take great care when selecting the tube for each application. Tubing should be fully annealed, seamless and drawn, suitable for bending and flaring, according to standard ASTM-269, A.I.S.I. 316 or 304.

### QUALITY

Lengths of finished tubing should be reasonably straight and have smooth ends, free from burrs. Tubing should be free from scale and injurious defects, and it should have a workmanlike finish. Surface imperfections such as handling marks, die marks, or shallow pits will not be considered injurious defects provided the imperfections are within the tolerances specified for diameter and wall thickness. The removal of such imperfections is not required. (Quality SAE J524).

### TUBE HANDLING

Scratches on the tube might cause leaks. It is, therefore, important to handle the tube carefully to reduce the risk of leaks.

1. Tubes must not be dragged on the floor.
2. Tubes must not be dragged out of a tubing rack, especially in cases of large OD tubes.

### TUBE CUTTING

Two different methods can be used to cut tubes:

1. Tube cutter
2. Hacksaw

#### Tube Cutter

To attain a leakfree connection, the tubing must be cut squarely. A good quality tube cutter with an appropriate blade for tubing material is recommended.

Do not try to reduce the time of cutting by taking deep cuts with each turn of the cutter.

The end of the tube must be deburred to avoid damage to the fitting and to ensure that the tube reaches the bottom of the fitting.

#### Hacksaw cutting

In order to cut the tube with a hacksaw and to attain square ends, the tube must be cut with guide blocks. This method of cutting requires deburring of the tube ends.

### WARNING

Do not hold the tube in a vise in the place where it will be inserted into the fitting. The vise will leave a mark on the tube that may cause leaks and might cause ovality.

## ASSEMBLY INSTRUCTIONS

Perform flaring according to SAE J533. See Fig. 2.  
See Table 1 below for dimensions.

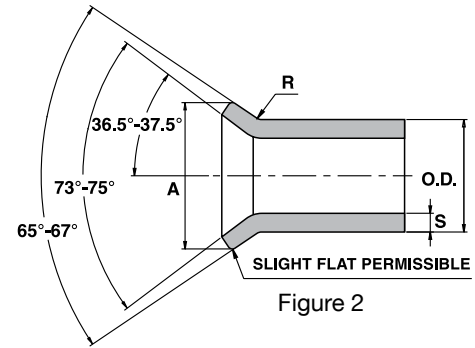

Figure 2

TABLE 1: FLARING

Nominal Tube O.D.	A Single Flare Diameter				R		S		DEBURRING PRIOR TO FLARING
	inch		mm		inch	mm	inch	mm	
	Max	Min	Max	Min	±0.02	±0.5	Max	Min	
1/8	0.20	0.18	5.08	4.58	0.03	0.8	0.035	0.88	To ensure satisfactory flare production, tube end deburring might be required prior to flaring. It is usually necessary to break the inside corner smoothly before single flaring. In addition, some non-ferrous tubing is normally required to eliminate the cutoff burr, which might otherwise create leakage paths across a substantial portion of the flare. Smoothly breaking the outside corner prior to single flaring, or both the outside and inside corners prior to double flaring, is acceptable for any tube material to minimize splitting.
3/16	0.28	0.26	7.11	6.61	0.03	0.8	0.035	0.88	
1/4	0.36	0.34	9.14	8.64	0.03	0.8	0.065	1.65	
5/16	0.43	0.40	10.92	10.16	0.03	0.8	0.065	1.65	
3/8	0.49	0.46	12.44	11.69	0.04	1.0	0.065	1.65	
1/2	0.66	0.63	16.76	16.01	0.06	1.5	0.083	2.1	
5/8	0.79	0.76	20.06	19.31	0.06	1.5	0.095	2.41	
3/4	0.95	0.92	24.13	23.37	0.08	2.0	0.109	2.76	
7/8	1.07	1.04	27.17	26.42	0.08	2.0	0.109	2.76	
1	1.20	1.17	30.48	29.72	0.09	2.3	0.12	3.04	
1 1/8	1.38	1.35	35.05	34.29	0.09	2.3	0.12	3.04	
1 1/4	1.51	1.48	38.35	37.60	0.09	2.3	0.12	3.04	
1 1/2	1.73	1.70	43.94	43.18	0.11	2.8	0.12	3.04	

Dimensions are for reference only, and subject to change without notice.

TABLE 2: ALLOWABLE WORKING PRESSURE RATINGS  
(CAPABLE OF 4" TO 1" MIN. BURST)

Nom. SAE Dash Size	Nom. Tube O.D. Inches	37° Flare Straight Thread	Nom. Pipe Size	SAE St.Threads Union and Bulkhead	Fittings with Pipe Threads	NOTE:
2	1/8	5/16" - 24	1/8"	5000	5000	As many factors influence the pressure at which a system will or will not perform satisfactorily, values shown in Table 2 should not be construed as guaranteed minimum.
3	3/16	3/8" - 24	1/8"	5000	5000	
4	1/4	7/16" - 20	1/8"	5000	5000	
5	5/16	1/2" - 20	1/8"	5000	5000	
6	3/8	9/16" - 18	1/4"	5000	5000	
8	1/2	3/4" - 16	3/8"	4500	4000	
10	5/8	7/8" - 14	1/2"	3500	3000	
12	3/4	1 1/16" - 12	3/4"	3500	3000	
14	7/8	1 3/16" - 12	3/4"	3000	2500	
16	1	1 5/16" - 12	1"	3000	2000	
20	1 1/4	1 5/8" - 12	1 1/4"	2500	1150	
24	1 1/2	1 7/8" - 12	1 1/2"	2000	1000	
32	2	2 1/2" - 12	2"	1500	1000	

## 37° FLARE INDEX

<b>SLEEVE</b> _____ <b>127</b> For 3-piece tube assembly S.A.E. 070115 740HF 	<b>FEMALE CONNECTOR</b> _____ <b>132</b> S.A.E. 070103 746HF 	<b>FEMALE RUN TEE</b> _____ <b>139</b> S.A.E. 070426 771HFL 
<b>NUT</b> _____ <b>127</b> For 3-piece tube assembly S.A.E. 070110 741HF 	<b>MALE CONNECTOR</b> _____ <b>133</b> S.A.E. 070102 748HF 	<b>FEMALE BRANCH TEE</b> _____ <b>140</b> S.A.E. 070427 772HFL 
<b>REDUCING ADAPTER</b> _____ <b>128</b> S.A.E. 070123 741HFL 	<b>MALE CONNECTOR</b> _____ <b>134</b> S.A.E. 0701120 748HOB 	<b>BULKHEAD UNION</b> _____ <b>141</b> S.A.E. 070601 774HFL 
<b>UNION</b> _____ <b>129</b> S.A.E. 070101 742HF 	<b>MALE ELBOW</b> _____ <b>135</b> S.A.E. 070202 749HF 	<b>BULKHEAD LOCKNUT</b> _____ <b>141</b> S.A.E. 070118 774HFLN 
<b>LARGE HEX UNION</b> _____ <b>129</b> S.A.E. 070119 742HFL 	<b>FEMALE ELBOW</b> _____ <b>136</b> S.A.E. 070203 750HF 	<b>CROSS</b> _____ <b>142</b> S.A.E. 070501 7102HFL 
<b>UNION TEE</b> _____ <b>130</b> S.A.E. 070401 744HF 	<b>MALE RUN TEE</b> _____ <b>137</b> S.A.E. 070424 751HF 	<b>TUBE PLUG</b> _____ <b>143</b> S.A.E. 070109 7639HF 
<b>MALE BRANCH TEE</b> _____ <b>131</b> S.A.E. 070425 745HF 	<b>UNION ELBOW</b> _____ <b>138</b> S.A.E. 070201 755HF 	<b>CAP</b> _____ <b>143</b> S.A.E. 070112 7640HF 

All 37° Flared Tube Fittings 3-Piece Tube Assembly can be used with a metric tube by using a metric 37° sleeve, instead of an inch sleeve. Each dimension table shows which metric sleeve should be used for every size.

**740 HF**

**SLEEVE FOR 3-PIECE  
TUBE ASSEMBLY**

S.A.E. 070115

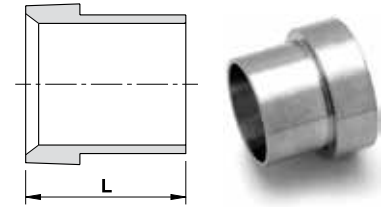

INCH SLEEVE			
Ordering Information	Tube O.D.		L
	inch	inch	mm
740HF SS 1/8"	1/8	0.34	8.6
740HF SS 3/16"	3/16	0.34	8.6
740HF SS 1/4"	1/4	0.41	10.4
740HF SS 5/16"	5/16	0.44	11.2
740HF SS 3/8"	3/8	0.50	12.7
740HF SS 1/2"	1/2	0.56	14.2
740HF SS 5/8"	5/8	0.66	16.8
740HF SS 3/4"	3/4	0.68	17.3
740HF SS 7/8"	7/8	0.76	19.3
740HF SS 1"	1	0.78	19.8
740HF SS 1 1/4"	1 1/4	0.91	23.1
740HF SS 1 1/2"	1 1/2	1.12	28.4
740HF SS 2"	2	1.19	30.2

METRIC SLEEVE		
Ordering Information	Tube O.D.	
	inch	mm
	-	-
	-	-
740HF SS 6MM	10.4	10.4
740HF SS 8MM	11.2	11.2
740HF SS 10MM	12.7	12.7
740HF SS 12MM	14.2	14.2
740HF SS 16MM	16.8	16.8
740HF SS 18MM	17.3	17.3
740HF SS 20MM	19.3	19.3
740HF SS 25MM	19.8	19.8
740HF SS 32MM	23.1	23.1
740HF SS 38MM	28.4	28.4

Metric sleeves are used with standard nuts & bodies.

**741 HF**

**NUT FOR 3-PIECE  
TUBE ASSEMBLY**

S.A.E. 070110

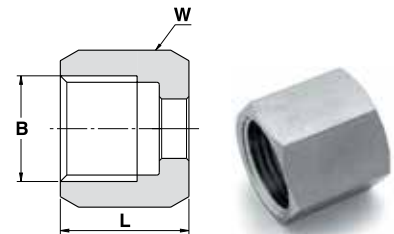

Ordering Information	Tube O.D.		B UN	W Hex. Flat	L	
	inch	mm		inch	inch	mm
741HF SS 1/8"	1/8	-	5/16 -24	3/8	0.54	13.7
741HF SS 3/16"	3/16	-	3/8 -24	7/16	0.60	15.2
741HF SS 1/4" / 6MM	1/4	6	7/16 -20	9/16	0.61	15.5
741HF SS 5/16" / 8MM	5/16	8	1/2 -20	5/8	0.67	17.0
741HF SS 3/8" / 10MM	3/8	10	9/16 -18	11/16	0.72	18.3
741HF SS 1/2" / 12MM	1/2	12	3/4 -16	7/8	0.84	21.3
741HF SS 5/8" / 16MM	5/8	16	7/8 -14	1	0.97	24.6
741HF SS 3/4" / 18MM	3/4	18	1 1/16 -12	1 1/4	1.02	25.9
741HF SS 7/8" / 20MM	7/8	20	1 3/16 -12	1 3/8	1.08	27.4
741HF SS 1" / 25MM	1	25	1 5/16 -12	1 1/2	1.12	28.4
741HF SS 1 1/4" / 32MM	1 1/4	32	1 5/8 -12	2	1.22	31.0
741HF SS 1 1/2" / 38MM	1 1/2	38	1 7/8 -12	2 1/4	1.41	35.8
741HF SS 2"	2	-	2 1/2 -12	2 7/8	1.74	44.2

"D" Dimension is minimum opening. Dimensions are for reference only, and are subject to change without notice.

## 741 HFL REDUCING ADAPTER

S.A.E. 070123

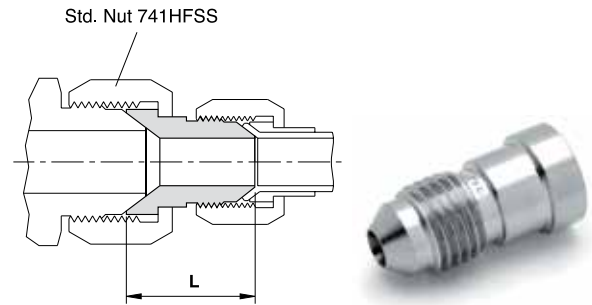

### TUBE (INCH)

Ordering Information	Tube O.D.	B UN	L	
	inch		inch	mm
741HFL SS 3/8" X 1/4"	3/8 to 1/4	7/16 - 20	0.97	24.6
741HFL SS 1/2" X 1/4"	1/2 to 1/4	7/16 - 20	1.00	25.4
741HFL SS 1/2" X 3/8"	1/2 to 3/8	9/16 - 18	1.00	25.4
741HFL SS 5/8" X 1/4"	5/8 to 1/4	7/16 - 20	1.03	26.2
741HFL SS 5/8" X 3/8"	5/8 to 3/8	9/16 - 18	1.03	26.2
741HFL SS 3/4" X 1/4"	3/4 to 1/4	7/16 - 20	1.09	27.7
741HFL SS 3/4" X 3/8"	3/4 to 3/8	9/16 - 18	1.09	27.7
741HFL SS 3/4" X 1/2"	3/4 to 1/2	3/4 - 16	1.19	30.2
741HFL SS 3/4" X 5/8"	3/4 to 5/8	7/8 - 14	1.66	42.1
741HFL SS 7/8" X 3/8"	7/8 to 3/8	9/16 - 18	1.13	28.7
741HFL SS 7/8" X 5/8"	7/8 to 5/8	7/8 - 14	1.33	33.7
741HFL SS 7/8" X 3/4"	7/8 to 3/4	1 1/16 - 12	1.84	46.7
741HFL SS 1" X 3/4"	1 to 3/4	1 1/16 - 12	1.47	37.3
741HFL SS 1" X 7/8"	1 to 7/8	1 3/16 - 12	1.91	48.5
741HFL SS 1 1/4" X 3/4"	1 1/4 to 3/4	1 1/16 - 12	1.53	38.8
741HFL SS 1 1/4" X 1"	1 1/4 to 1	1 5/16 - 12	1.59	40.3
741HFL SS 1 1/2" X 1 1/4"	1 1/2 to 1 1/4	1 5/8 - 12	1.69	42.9

### TUBE (MM)

Ordering Information	Tube O.D.	B UN	L	
	inch to mm		inch	mm
741HFL SS 3/8" X 6MM	3/8 to 6	7/16 - 20	0.97	24.6
741HFL SS 1/2" X 6MM	1/2 to 6	7/16 - 20	1.00	25.4
741HFL SS 1/2" X 10MM	1/2 to 10	9/16 - 18	1.00	25.4
741HFL SS 5/8" X 6MM	5/8 to 6	7/16 - 20	1.03	26.2
741HFL SS 5/8" X 10MM	5/8 to 10	9/16 - 18	1.03	26.2
741HFL SS 5/8" X 12MM	5/8 to 12	3/4 - 16	1.44	36.5
741HFL SS 3/4" X 6MM	3/4 to 6	7/16 - 20	1.09	27.7
741HFL SS 3/4" X 10MM	3/4 to 10	9/16 - 18	1.09	27.7
741HFL SS 3/4" X 12MM	3/4 to 12	3/4 - 16	1.19	30.2
741HFL SS 3/4" X 16MM	3/4 to 16	7/8 - 14	1.66	42.1
741HFL SS 7/8" X 10MM	7/8 to 10	9/16 - 18	1.13	28.7
741HFL SS 7/8" X 16MM	7/8 to 16	7/8 - 14	1.33	33.7
741HFL SS 7/8" X 18MM	7/8 to 18	1 1/16 - 12	1.84	46.7
741HFL SS 1" X 18MM	1 to 18	1 1/16 - 12	1.47	37.3
741HFL SS 1" X 20MM	1 to 20	1 3/16 - 12	1.91	48.5
741HFL SS 1 1/4" X 18MM	1 1/4 to 18	1 1/16 - 12	1.53	38.8
741HFL SS 1 1/4" X 25MM	1 1/4 to 25	1 5/16 - 12	1.59	40.3
741HFL SS 1 1/2" X 32MM	1 1/2 to 32	1 5/8 - 12	1.69	42.9

"D" Dimension is minimum opening. Dimensions are for reference only, and are subject to change without notice.

**742 HF**  
**UNION**  
 S.A.E. 070101

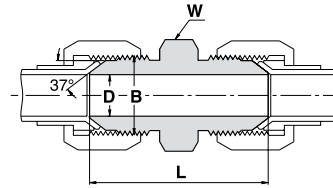

Ordering Information	Tube O.D.		B UN	D		W Hex. Flat	L	
	inch	mm		inch	mm		inch	inch
742HF SS 1/8"	1/8	-	5/16 - 24	0.062	1.6	7/16	1.17	29.7
742HF SS 3/16"	3/16	-	3/8 - 24	0.125	3.2	7/16	1.23	31.2
742HF SS 1/4" / 6MM	1/4	6	7/16 - 20	0.172	4.4	1/2	1.37	34.8
742HF SS 5/16" / 8MM	5/16	8	1/2 - 20	0.234	6.0	9/16	1.37	34.8
742HF SS 3/8" / 10MM	3/8	10	9/16 - 18	0.297	7.5	5/8	1.41	35.8
742HF SS 1/2" / 12MM	1/2	12	3/4 - 16	0.391	9.9	13/16	1.62	41.1
742HF SS 5/8" / 16MM	5/8	16	7/8 - 14	0.484	12.3	15/16	1.88	47.8
742HF SS 3/4" / 18MM	3/4	18	1 1/16 - 12	0.609	15.5	1 1/8	2.16	54.9
742HF SS 7/8" / 20MM	7/8	20	1 3/16 - 12	0.719	18.3	1 1/4	2.21	56.1
742HF SS 1" / 25MM	1	25	1 5/16 - 12	0.844	21.5	1 3/8	2.25	57.2
742HF SS 1 1/4" / 32MM	1 1/4	32	1 5/8 - 12	1.078	27.5	1 11/16	2.43	61.7
742HF SS 1 1/2" / 38MM	1 1/2	38	1 7/8 - 12	1.312	33.0	2	2.75	69.8
742HF SS 2"	2	-	2 1/2 - 12	1.781	45.0	2 5/8	3.04	86.4

**742 HFL**  
**LARGE HEX UNION**  
 S.A.E. 070119

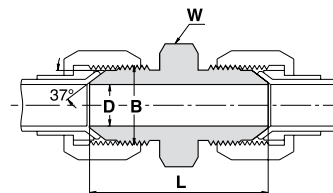

Ordering Information	Tube O.D.		B UN	D		W Hex. Flat	L	
	inch	mm		inch	mm		inch	inch
742HFL SS 1/8"	1/8	-	5/16 - 24	0.062	1.6	9/16	1.17	29.7
742HFL SS 3/16"	3/16	-	3/8 - 24	0.125	3.2	5/8	1.23	31.2
742HFL SS 1/4" / 6MM	1/4	6	7/16 - 20	0.172	4.4	11/16	1.37	34.8
742HFL SS 5/16" / 8MM	5/16	8	1/2 - 20	0.234	6.0	3/4	1.37	34.8
742HFL SS 3/8" / 10MM	3/8	10	9/16 - 18	0.297	7.5	13/16	1.41	35.8
742HFL SS 1/2" / 12MM	1/2	12	3/4 - 16	0.391	9.9	1	1.62	41.1
742HFL SS 5/8" / 16MM	5/8	16	7/8 - 14	0.484	12.3	1 1/8	1.88	47.8
742HFL SS 3/4" / 18MM	3/4	18	1 1/16 - 12	0.609	15.5	1 3/8	2.16	54.9
742HFL SS 7/8" / 20MM	7/8	20	1 3/16 - 12	0.719	18.3	1 1/2	2.21	56.1
742HFL SS 1" / 25MM	1	25	1 5/16 - 12	0.844	21.5	1 5/8	2.25	57.2
742HFL SS 1 1/4" / 32MM	1 1/4	32	1 5/8 - 12	1.078	27.5	1 7/8	2.43	61.7
742HFL SS 1 1/2" / 38MM	1 1/2	38	1 7/8 - 12	1.312	33.0	2 1/8	2.75	69.8
742HFL SS 2"	2	-	2 1/2 - 12	1.781	45.0	2 3/4	3.04	86.4

"D" Dimension is minimum opening. Dimensions are for reference only, and are subject to change without notice.

**744 HF**  
**UNION TEE**  
 S.A.E. 070401

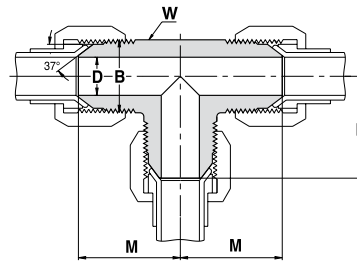

Ordering Information	Tube O.D.		B UN	D		W Wrench Flat	M	
	inch	mm		inch	mm		inch	inch
744HF SS 1/8"	1/8	-	5/16 - 24	0.062	1.6	7/16	0.77	19.6
744HF SS 3/16"	3/16	-	3/8 - 24	0.125	3.2	1/2	0.83	21.1
744HF SS 1/4" / 6MM	1/4	6	7/16 - 20	0.172	4.4	1/2	0.89	22.6
744HF SS 5/16" / 8MM	5/16	8	1/2 - 20	0.234	6.0	5/8	0.95	24.1
744HF SS 3/8" / 10MM	3/8	10	9/16 - 18	0.297	7.5	5/8	1.06	26.9
744HF SS 1/2" / 12MM	1/2	12	3/4 - 16	0.391	9.9	15/16	1.25	31.8
744HF SS 5/8" / 16MM	5/8	16	7/8 - 14	0.484	12.3	15/16	1.45	36.8
744HF SS 3/4" / 18MM	3/4	18	1 1/16 - 12	0.609	15.5	1 3/8	1.66	42.2
744HF SS 7/8" / 20MM	7/8	20	1 3/16 - 12	0.719	18.3	1 3/8	1.80	45.7
744HF SS 1" / 25MM	1	25	1 5/16 - 12	0.844	21.5	1 3/8	1.81	46.0
744HF SS 1 1/4" / 32MM	1 1/4	32	1 5/8 - 12	1.078	27.5	2	2.06	52.3
744HF SS 1 1/2" / 38MM	1 1/2	38	1 7/8 - 12	1.312	33.0	*2	2.33	59.2
744HF SS 2"	2	-	2 1/2 - 12	1.781	45.0	*2 5/8	3.06	77.7

\*Not from Forging

"D" Dimension is minimum opening. Dimensions are for reference only, and are subject to change without notice.



**745 HF**

**MALE BRANCH TEE**

S.A.E. 070425

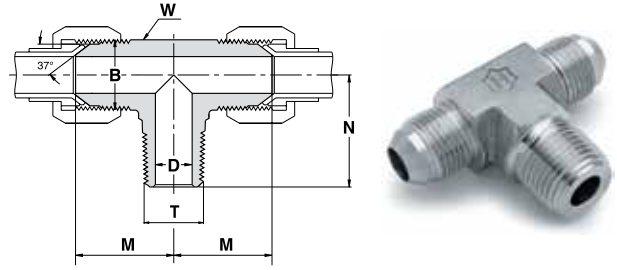

Ordering Information	Tube O.D.		B UN	T NPT	D		W Wrench Flat	M		N	
	inch	mm			inch	mm		inch	mm	inch	mm
745HF SS 1/8" X 1/8"	1/8	-	5/16 - 24	1/8 - 27	0.062	1.6	7/16	0.77	19.6	0.72	18.3
745HF SS 3/16" X 1/8"	3/16	-	3/8 - 24	1/8 - 27	0.125	3.2	1/2	0.83	21.1	0.72	18.3
745HF SS 1/4" / 6MM X 1/8"	1/4	6	7/16 - 20	1/8 - 27	0.172	4.4	1/2	0.89	22.6	0.78	19.8
745HF SS 1/4" / 6MM X 1/4"	1/4	6	7/16 - 20	1/4 - 18	0.172	4.4	5/8	1.06	26.9	1.09	27.7
745HF SS 5/16" / 8MM X 1/8"	5/16	8	1/2 - 20	1/8 - 27	0.190	4.8	5/8	0.95	24.1	0.78	19.8
745HF SS 5/16" / 8MM X 1/4"	5/16	8	1/2 - 20	1/4 - 18	0.234	6.0	5/8	1.06	26.9	1.09	27.7
745HF SS 3/8" / 10MM X 1/8"	3/8	10	9/16 - 18	1/8 - 27	0.190	4.8	5/8	1.06	26.9	0.90	22.8
745HF SS 3/8" / 10MM X 1/4"	3/8	10	9/16 - 18	1/4 - 18	0.280	7.1	5/8	1.06	26.9	1.09	27.7
745HF SS 3/8" / 10MM X 3/8"	3/8	10	9/16 - 18	3/8 - 18	0.297	7.5	13/16	1.14	29.0	1.22	31.0
745HF SS 3/8" / 10MM X 1/2"	3/8	10	9/16 - 18	1/2 - 14	0.297	7.5	15/16	1.23	31.2	1.47	37.3
745HF SS 1/2" / 12MM X 1/4"	1/2	12	3/4 - 16	1/4 - 18	0.280	7.1	15/16	1.25	31.8	1.22	31.0
745HF SS 1/2" / 12MM X 3/8"	1/2	12	3/4 - 16	3/8 - 18	0.380	9.5	15/16	1.25	31.8	1.22	31.0
745HF SS 1/2" / 12MM X 1/2"	1/2	12	3/4 - 16	1/2 - 14	0.391	9.9	15/16	1.33	33.7	1.47	37.3
745HF SS 1/2" / 12MM X 3/4"	1/2	12	3/4 - 16	3/4 - 14	0.391	9.9	1 1/8	1.42	36.0	1.59	40.4
745HF SS 5/8" / 16MM X 3/8"	5/8	16	7/8 - 14	3/8 - 18	0.380	9.5	15/16	1.45	36.8	1.30	33.0
745HF SS 5/8" / 16MM X 1/2"	5/8	16	7/8 - 14	1/2 - 14	0.470	11.9	15/16	1.45	36.8	1.47	37.3
745HF SS 5/8" / 16MM X 3/4"	5/8	16	7/8 - 14	3/4 - 14	0.484	12.3	1 1/8	1.53	38.9	1.59	40.4
745HF SS 3/4" / 18MM X 1/2"	3/4	18	1 1/16 - 12	1/2 - 14	0.470	11.9	1 1/8	1.66	41.0	1.59	40.4
745HF SS 3/4" / 18MM X 3/4"	3/4	18	1 1/16 - 12	3/4 - 14	0.609	15.5	1 1/8	1.66	41.0	1.59	40.4
745HF SS 7/8" / 20MM X 3/4"	7/8	20	1 3/16 - 12	3/4 - 14	0.719	18.3	1 3/8	1.73	43.9	1.69	42.9
745HF SS 1" / 25MM X 3/4"	1	25	1 5/16 - 12	3/4 - 14	0.719	18.3	1 3/8	1.81	46.0	1.78	45.2
745HF SS 1" / 25 MM X 1"	1	25	1 5/16 - 12	1-11.5	0.844	21.5	1 3/8	1.81	46.0	1.97	50.0
745HF SS 1 1/4" / 32 MM X 1"	1 1/4	32	1 5/8 - 12	1-11.5	0.844	21.5	*2	2.06	52.3	2.35	59.6
745HF SS 1 1/4" / 32 MM X 1 1/4"	1 1/4	32	1 5/8 - 12	1 1/4 -11.5	1.078	27.5	*2	2.06	52.3	2.38	60.5
745HF SS 1 1/2" / 38 MM X 1 1/2"	1 1/2	38	1 7/8 - 12	1 1/2 -11.5	1.312	33.0	*2	2.33	59.2	2.64	67.1
745HF SS 2" X 2"	2	-	1 7/8 - 12	2-11.5	1.781	45.0	*2 5/8	3.06	77.7	3.00	76.2

\*Not from Forging

"D" Dimension is minimum opening. Dimensions are for reference only, and are subject to change without notice.

**746 HF****FEMALE CONNECTOR**

S.A.E. 070103

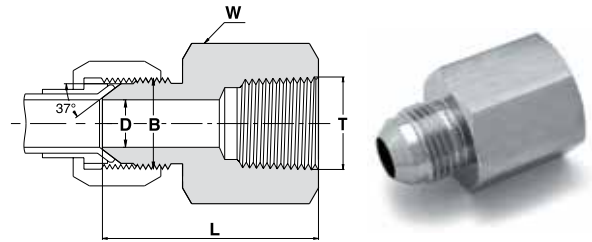

Ordering Information	Tube O.D.		B UN	T NPT	D		W Hex. Flat	L	
	inch	mm			inch	mm		inch	inch
746HF SS 1/8" X 1/8"	1/8	-	5/16 - 24	1/8 - 27	0.062	1.6	9/16	1.12	28.4
746HF SS 3/16" X 1/8"	3/16	-	3/8 - 24	1/8 - 27	0.125	3.2	9/16	1.13	28.7
746HF SS 1/4" / 6MM X 1/8"	1/4	6	7/16 - 20	1/8 - 27	0.172	4.4	9/16	1.19	30.2
746HF SS 1/4" / 6MM X 1/4"	1/4	6	7/16 - 20	1/4 - 18	0.172	4.4	3/4	1.39	35.3
746HF SS 5/16" / 8MM X 1/8"	5/16	8	1/2 - 20	1/8 - 27	0.234	6.0	9/16	1.17	29.7
746HF SS 5/16" / 8MM X 1/4"	5/16	8	1/2 - 20	1/4 - 18	0.234	6.0	3/4	1.39	35.3
746HF SS 3/8" / 10MM X 1/4"	3/8	10	9/16 - 18	1/4 - 18	0.297	7.5	3/4	1.40	35.6
746HF SS 3/8" / 10MM X 3/8"	3/8	10	9/16 - 18	3/8 - 18	0.297	7.5	7/8	1.46	37.1
746HF SS 1/2" / 12MM X 3/8"	1/2	12	3/4 - 16	3/8 - 18	0.391	9.9	7/8	1.56	39.6
746HF SS 1/2" / 12MM X 1/2"	1/2	12	3/4 - 16	1/2 - 14	0.391	9.9	1 1/8	1.79	45.6
746HF SS 5/8" / 16MM X 1/2"	5/8	16	7/8 - 14	1/2 - 14	0.484	12.3	1 1/8	1.89	48.0
746HF SS 3/4" / 18MM X 1/2"	3/4	18	1 1/16 - 12	1/2 - 14	0.609	15.5	1 1/8	2.05	52.1
746HF SS 3/4" / 18MM X 3/4"	3/4	18	1 1/16 - 12	3/4 - 14	0.609	15.5	1 3/8	2.06	52.3
746HF SS 7/8" / 20MM X 3/4"	7/8	20	1 3/16 - 12	3/4 - 14	0.719	18.3	1 3/8	2.06	52.3
746HF SS 1" / 25MM X 1"	1	25	1 5/16 - 12	1 - 11.5	0.844	21.5	1 5/8	2.35	59.7
746HF SS 1 1/4" / 32MM X 1 1/4"	1 1/4	32	1 5/8 - 12	1 1/4 - 11.5	1.078	27.5	2	2.49	63.2
746HF SS 1 1/2" / 38MM X 1 1/2"	1 1/2	38	1 7/8 - 12	1 1/2 - 11.5	1.312	33.0	2 3/8	2.62	66.5
746HF SS 2" X 2"	2	-	2 1/2 - 12	2 - 11.5	1.781	45.0	2 7/8	2.97	75.4

"D" Dimension is minimum opening. Dimensions are for reference only, and are subject to change without notice.

**748 HF**

**MALE CONNECTOR**

S.A.E. 070102

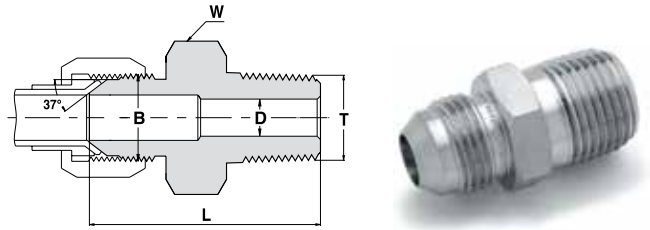

Ordering Information	Tube O.D.		B UN	T NPT	D		W Hex. Flat	L	
	inch	mm			inch	mm		inch	mm
748HF SS 1/8" X 1/8"	1/8	-	5/16 - 24	1/8 - 27	0.062	1.6	7/16	1.11	28.2
748HF SS 3/16" X 1/8"	3/16	-	3/8 - 24	1/8 - 27	0.125	3.2	7/16	1.14	29.0
748HF SS 1/4" / 6MM X 1/8"	1/4	6	7/16 - 20	1/8 - 27	0.172	4.4	1/2	1.22	31.0
748HF SS 1/4" / 6MM X 1/4"	1/4	6	7/16 - 20	1/4 - 18	0.172	4.4	9/16	1.42	36.0
748HF SS 1/4" / 6MM X 1/2"	1/4	6	7/16 - 20	1/2 - 14	0.172	4.4	7/8	1.61	41.0
748HF SS 5/16" / 8MM X 1/8"	5/16	8	1/2 - 20	1/8 - 27	0.190	4.8	9/16	1.22	31.0
748HF SS 5/16" / 8MM X 1/4"	5/16	8	1/2 - 20	1/4 - 18	0.234	6.0	9/16	1.42	36.1
748HF SS 3/8" / 10MM X 1/8"	3/8	10	9/16 - 18	1/8 - 27	0.190	4.8	5/8	1.25	31.8
748HF SS 3/8" / 10MM X 1/4"	3/8	10	9/16 - 18	1/4 - 18	0.280	7.1	5/8	1.43	36.3
748HF SS 3/8" / 10MM X 3/8"	3/8	10	9/16 - 18	3/8 - 18	0.297	7.5	3/4	1.43	36.3
748HF SS 3/8" / 10MM X 1/2"	3/8	10	9/16 - 18	1/2 - 14	0.297	7.5	7/8	1.69	42.5
748HF SS 1/2" / 12MM X 1/4"	1/2	12	3/4 - 16	1/4 - 18	0.280	7.1	13/16	1.53	38.9
748HF SS 1/2" / 12MM X 3/8"	1/2	12	3/4 - 16	3/8 - 18	0.380	9.5	13/16	1.53	38.9
748HF SS 1/2" / 12MM X 1/2"	1/2	12	3/4 - 16	1/2 - 14	0.391	9.9	7/8	1.79	45.4
748HF SS 1/2" / 12MM X 3/4"	1/2	12	3/4 - 16	3/4 - 14	0.391	9.9	1 1/8	1.85	47.0
748HF SS 5/8" / 16MM X 3/8"	5/8	16	7/8 - 14	3/8 - 18	0.380	9.5	15/16	1.70	43.1
748HF SS 5/8" / 16MM X 1/2"	5/8	16	7/8 - 14	1/2 - 14	0.484	11.9	15/16	1.89	48.0
748HF SS 5/8" / 16MM X 3/4"	5/8	16	7/8 - 14	3/4 - 14	0.470	12.3	1 1/8	1.95	49.5
748HF SS 3/4" / 18MM X 3/4"	3/4	18	1 1/16 - 12	3/4 - 14	0.609	15.5	1 1/8	2.06	52.3
748HF SS 3/4" / 18MM X 1"	3/4	18	1 1/16 - 12	1 - 11.5	0.609	15.5	1 3/8	2.25	57.1
748HF SS 7/8" / 20MM X 3/4"	7/8	20	1 3/16 - 12	3/4 - 14	0.719	18.3	1 1/4	2.09	53.1
748HF SS 1" / 25MM X 3/4"	1	25	1 5/16 - 12	3/4 - 14	0.719	18.3	1 3/8	2.11	53.5
748HF SS 1" / 25MM X 1"	1	25	1 5/16 - 12	1 - 11.5	0.844	21.5	1 3/8	2.30	58.4
748HF SS 1 1/4" / 32MM X 1"	1 1/4	32	1 5/8 - 12	1 - 11.5	0.844	21.5	1 3/4	2.42	61.5
748HF SS 1 1/4" / 32MM X 1 1/4"	1 1/4	32	1 5/8 - 12	1 1/4 - 11.5	1.078	27.5	1 3/4	2.45	62.2
748HF SS 1 1/2" / 38MM X 1 1/4"	1 1/2	38	1 7/8 - 12	1 1/4 - 11.5	1.312	33.0	2	2.68	68.1
748HF SS 1 1/2" / 38MM X 1 1/2"	1 1/2	38	1 7/8 - 12	1 1/2 - 11.5	1.312	33.0	2	2.68	68.1
748HF SS 2" X 2"	2	-	2 1/2 - 12	2 - 11.5	1.781	45.0	2 5/8	3.11	79.0

"D" Dimension is minimum opening. Dimensions are for reference only, and are subject to change without notice.

**748 HOB****MALE CONNECTOR**

SAE straight thread boss connects flared tube ends to straight thread boss S.A.E. 070120

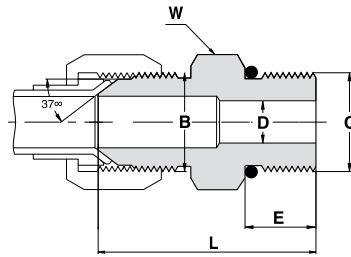

Ordering Information	Tube O.D.		B UN	C UN	D		W Hex. Flat	E		L		O-Ring STD. Dash No.
	inch	mm			inch	mm		inch	mm	inch	mm	
748HOB SS 1/8" X 5/16"-24	1/8	-	5/16 - 24	5/16 - 24	0.062	1.6	7/16	0.30	7.5	1.06	26.9	-902
748HOB SS 3/16" X 3/8"-24	3/16	-	3/8 - 24	3/8 - 24	0.125	3.2	1/2	0.30	7.5	1.10	27.9	-903
748HOB SS 1/4" / 6MM X 7/16"-20	1/4	6	7/16 - 20	7/16 - 20	0.172	4.4	9/16	0.36	9.1	1.23	31.2	-904
748HOB SS 1/4" / 6MM X 1/2"-20	1/4	6	7/16 - 20	1/2 - 20	0.172	4.4	5/8	0.36	9.1	1.23	31.2	-905
748HOB SS 1/4" / 6MM X 9/16"-18	1/4	6	7/16 - 20	9/16 - 18	0.172	4.4	11/16	0.39	9.9	1.30	33.0	-906
748HOB SS 1/4" / 6MM X 3/4"-16	1/4	6	7/16 - 20	3/4 - 16	0.172	4.4	7/8	0.44	11.1	1.37	34.8	-908
748HOB SS 5/16" / 8MM X 1/2"-20	5/16	8	1/2 - 20	1/2 - 20	0.234	6.0	5/8	0.36	9.1	1.23	31.2	-905
748HOB SS 3/8" / 10MM X 9/16"-18	3/8	10	9/16 - 18	9/16 - 18	0.280	7.1	11/16	0.39	9.9	1.30	33.0	-906
748HOB SS 3/8" / 10MM X 3/4"-16	3/8	10	9/16 - 18	3/4 - 16	0.297	7.5	7/8	0.44	11.1	1.38	35.1	-908
748HOB SS 3/8" / 10MM X 7/8"-14	3/8	10	9/16 - 18	7/8 - 14	0.297	7.5	1	0.50	12.7	1.50	38.1	-910
748HOB SS 1/2" / 12MM X 3/4"-16	1/2	12	3/4 - 16	3/4 - 16	0.391	9.9	7/8	0.44	11.1	1.48	37.6	-908
748HOB SS 1/2" / 12MM X 9/16"-18	1/2	12	3/4 - 16	9/16 - 18	0.280	7.1	13/16	0.39	9.9	1.44	36.6	-906
748HOB SS 1/2" / 12MM X 7/8"-14	1/2	12	3/4 - 16	7/8 - 14	0.391	9.9	1	0.50	12.7	1.60	40.6	-910
748HOB SS 1/2" / 12MM X 1 1/16"-12	1/2	12	3/4 - 16	1 1/16 - 12	0.391	9.9	1 1/4	0.59	15.1	1.76	44.7	-912
748HOB SS 5/8" / 16MM X 7/8"-14	5/8	16	7/8 - 14	7/8 - 14	0.484	12.3	1	0.50	12.7	1.70	43.2	-910
748HOB SS 5/8" / 16MM X 3/4"-16	5/8	16	7/8 - 14	3/4 - 16	0.484	12.3	15/16	0.44	11.1	1.60	40.6	-908
748HOB SS 5/8" / 16MM X 1 1/16"-12	5/8	16	7/8 - 14	1 1/16 - 12	0.484	12.3	1 1/4	0.59	15.1	1.86	47.2	-912
748HOB SS 3/4" / 18MM X 1 1/16"-12	3/4	18	1 1/16 - 12	1 1/16 - 12	0.609	15.5	1 1/4	0.59	15.1	1.97	50.0	-912
748HOB SS 3/4" / 18MM X 3/4"-16	3/4	18	1 1/16 - 12	3/4 - 16	0.420	10.7	1 1/8	0.44	11.1	1.78	45.2	-908
748HOB SS 3/4" / 18MM X 7/8"-14	3/4	18	1 1/16 - 12	7/8 - 14	0.50	12.7	1 1/8	0.50	12.7	1.83	46.4	-910
748HOB SS 3/4" / 18MM X 1 5/16"-12	3/4	18	1 1/16 - 12	1 5/16 - 12	0.609	15.5	1 1/2	0.59	15.1	2.00	50.8	-916
748HOB SS 7/8" / 20MM X 1 3/16"-12	7/8	20	1 3/16 - 12	1 3/16 - 12	0.719	18.3	1 3/8	0.59	15.1	1.99	50.5	-914
748HOB SS 7/8" / 20MM X 1 5/16"-12	7/8	20	1 3/16 - 12	1 5/16 - 12	0.719	18.3	1 1/2	0.59	15.1	2.02	51.3	-916
748HOB SS 1" / 25MM X 1 1/16"-12	1	25	1 5/16 - 12	1 1/16 - 12	0.650	16.7	1 3/8	0.59	15.1	2.01	51.1	-912
748HOB SS 1" / 25MM X 1 3/16"-12	1	25	1 5/16 - 12	1 3/16 - 12	0.719	18.3	1 3/8	0.59	15.1	2.04	51.8	-914
748HOB SS 1" / 25MM X 1 5/16"-12	1	25	1 5/16 - 12	1 5/16 - 12	0.844	21.5	1 1/2	0.59	15.1	2.04	51.8	-916

"D" Dimension is minimum opening. Dimensions are for reference only, and are subject to change without notice.

**749 HF**  
**MALE ELBOW**  
 S.A.E. 070202

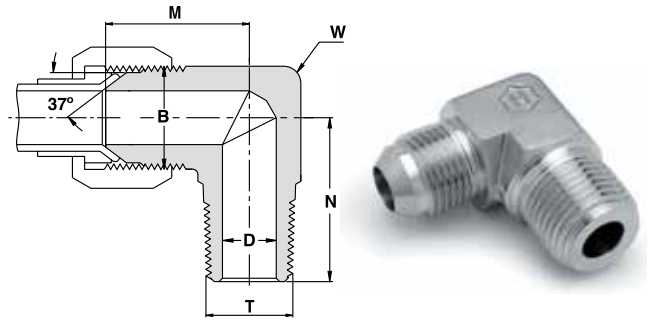

Ordering Information	Tube O.D.		B UN	T NPT	D		W Wrench Flat	M		N	
	inch	mm			inch	mm		inch	mm	inch	mm
749HF SS 1/8" X 1/8"	1/8	-	5/16 - 24	1/8 - 27	0.062	1.6	7/16	0.77	19.6	0.72	18.3
749HF SS 3/16" X 1/8"	3/16	-	3/8 - 24	1/8 - 27	0.125	3.2	1/2	0.83	21.1	0.72	18.3
749HF SS 1/4" / 6MM X 1/8"	1/4	6	7/16 - 20	1/8 - 27	0.172	4.4	1/2	0.89	22.6	0.78	19.8
749HF SS 1/4" / 6MM X 1/4"	1/4	6	7/16 - 20	1/4 - 18	0.172	4.4	5/8	1.06	26.9	1.09	27.7
749HF SS 5/16" / 8MM X 1/8"	5/16	8	1/2 - 20	1/8 - 27	0.190	4.8	5/8	0.95	24.1	0.78	19.8
749HF SS 5/16" / 8MM X 1/4"	5/16	8	1/2 - 20	1/4 - 18	0.234	6.0	5/8	1.06	26.9	1.09	27.7
749HF SS 3/8" / 10MM X 1/8"	3/8	10	9/16 - 18	1/8 - 27	0.190	4.8	5/8	1.06	26.9	0.90	22.8
749HF SS 3/8" / 10MM X 1/4"	3/8	10	9/16 - 18	1/4 - 18	0.280	7.1	5/8	1.06	26.9	1.09	27.7
749HF SS 3/8" / 10MM X 3/8"	3/8	10	9/16 - 18	3/8 - 18	0.297	7.5	13/16	1.14	29.0	1.22	31.0
749HF SS 3/8" / 10MM X 1/2"	3/8	10	9/16 - 18	1/2 - 14	0.297	7.5	15/16	1.23	31.2	1.47	37.3
749HF SS 1/2" / 12MM X 1/4"	1/2	12	3/4 - 16	1/4 - 18	0.280	7.1	15/16	1.25	31.8	1.22	31.0
749HF SS 1/2" / 12MM X 3/8"	1/2	12	3/4 - 16	3/8 - 18	0.380	9.5	15/16	1.25	31.8	1.22	31.0
749HF SS 1/2" / 12MM X 1/2"	1/2	12	3/4 - 16	1/2 - 14	0.391	9.9	15/16	1.33	33.7	1.47	37.3
749HF SS 1/2" / 12MM X 3/4"	1/2	12	3/4 - 16	3/4 - 14	0.391	9.9	1 1/8	1.42	36.0	1.59	40.4
749HF SS 5/8" / 16MM X 3/8"	5/8	16	7/8 - 14	3/8 - 18	0.380	9.5	15/16	1.45	36.8	1.30	33.0
749HF SS 5/8" / 16MM X 1/2"	5/8	16	7/8 - 14	1/2 - 14	0.470	11.9	15/16	1.45	36.8	1.47	37.3
749HF SS 5/8" / 16MM X 3/4"	5/8	16	7/8 - 14	3/4 - 14	0.484	12.3	1 1/8	1.53	38.9	1.59	40.4
749HF SS 3/4" / 18MM X 1/2"	3/4	18	1 1/16 - 12	1/2 - 14	0.470	11.9	1 1/8	1.66	41.0	1.59	40.4
749HF SS 3/4" / 18MM X 3/4"	3/4	18	1 1/16 - 12	3/4 - 14	0.609	15.5	1 1/8	1.66	41.0	1.59	40.4
749HF SS 7/8" / 20MM X 3/4"	7/8	20	1 3/16 - 12	3/4 - 14	0.719	18.3	1 3/8	1.73	43.9	1.69	42.9
749HF SS 1" / 25MM X 3/4"	1	25	1 5/16 - 12	3/4 - 14	0.719	18.3	1 3/8	1.81	46.0	1.78	45.2
749HF SS 1" / 25MM X 1"	1	25	1 5/16 - 12	1-11.5	0.844	21.5	1 3/8	1.81	46.0	1.97	50.0
749HF SS 1 1/4" / 32MM X 1"	1 1/4	32	1 5/8 - 12	1-11.5	0.844	21.5	2	2.06	52.3	2.35	59.6
749HF SS 1 1/4" / 32MM X 1 1/4"	1 1/4	32	1 5/8 - 12	1 1/4 - 11.5	1.078	27.5	2	2.06	52.3	2.38	60.5
749HF SS 1 1/2" / 38MM X 1 1/2"	1 1/2	38	1 7/8 - 12	1 1/2 - 11.5	1.312	33.0	*2	2.33	59.2	2.64	67.1
749HF SS 2" X 2"	2	-	2 1/2 - 12	2 - 11.5	1.781	45.0	*2 5/8	3.06	77.7	3.00	76.2

\*Not from Forging

"D" Dimension is minimum opening. Dimensions are for reference only, and are subject to change without notice.

**750 HF**  
**FEMALE ELBOW**  
 S.A.E. 070203

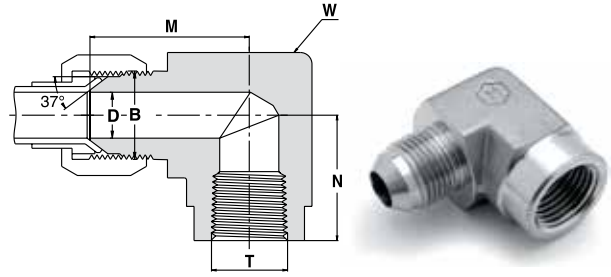

Ordering Information	Tube O.D.		B UN	T NPT	D		W Wrench Flat	M		N	
	inch	mm			inch	mm		inch	mm	inch	mm
750HF SS 1/8" X 1/8"	1/8	-	5/16 - 24	1/8 - 27	0.062	1.6	5/8	1.00	25.4	0.66	16.8
750HF SS 3/16" X 1/8"	3/16	-	3/8 - 24	1/8 - 27	0.125	3.2	5/8	1.03	26.2	0.66	16.8
750HF SS 1/4" / 6MM X 1/8"	1/4	6	7/16 - 20	1/8 - 27	0.172	4.4	5/8	1.08	27.4	0.66	16.8
750HF SS 1/4" / 6MM X 1/4"	1/4	6	7/16 - 20	1/4 - 18	0.172	4.4	13/16	1.22	30.9	0.88	22.4
750HF SS 5/16" / 8MM X 1/8"	5/16	8	1/2 - 20	1/8 - 27	0.234	6.0	5/8	1.08	27.4	0.66	16.8
750HF SS 5/16" / 8MM X 1/4"	5/16	8	1/2 - 20	1/4 - 18	0.234	6.0	13/16	1.22	30.9	0.88	22.4
750HF SS 3/8" / 10MM X 1/8"	3/8	10	9/16 - 18	1/8 - 27	0.297	7.5	5/8	1.06	26.9	0.66	16.8
750HF SS 3/8" / 10MM X 1/4"	3/8	10	9/16 - 18	1/4 - 18	0.297	7.5	13/16	1.23	31.2	0.88	22.4
750HF SS 3/8" / 10MM X 3/8"	3/8	10	9/16 - 18	3/8 - 18	0.297	7.5	15/16	1.31	33.2	1.02	25.9
750HF SS 1/2" / 12MM X 1/4"	1/2	12	3/4 - 16	1/4 - 18	0.391	9.9	13/16	1.25	31.6	0.88	22.4
750HF SS 1/2" / 12MM X 3/8"	1/2	12	3/4 - 16	3/8 - 18	0.391	9.9	15/16	1.42	36.1	1.02	25.9
750HF SS 1/2" / 12MM X 1/2"	1/2	12	3/4 - 16	1/2 - 14	0.391	9.9	1 1/8	1.42	36.1	1.23	31.2
750HF SS 5/8" / 16MM X 1/2"	5/8	16	7/8 - 14	1/2 - 14	0.484	12.3	1 1/8	1.64	41.5	1.23	31.2
750HF SS 3/4" / 18MM X 1/2"	3/4	18	1 1/16 - 12	1/2 - 14	0.609	15.5	1 3/8	1.66	42.1	1.23	31.2
750HF SS 3/4" / 18MM X 3/4"	3/4	18	1 1/16 - 12	3/4 - 14	0.609	15.5	1 3/8	1.89	48.0	1.36	34.5
750HF SS 7/8" / 20MM X 3/4"	7/8	20	1 3/16 - 12	3/4 - 14	0.719	18.3	1 3/8	1.86	47.2	1.42	36.1
750HF SS 1" / 25MM X 1"	1	25	1 5/16 - 12	1 - 11.5	0.844	21.5	1 5/8	2.17	55.1	1.62	41.1
750HF SS 1 1/4" / 32MM X 1 1/4"	1 1/4	32	1 5/8 - 12	1 1/4 - 11.5	1.078	27.5	*2 1/8	2.33	59.2	1.70	43.2
750HF SS 1 1/2" / 38MM X 1 1/2"	1 1/2	38	1 7/8 - 12	1 1/2 - 11.5	1.312	33.0	*2 3/8	2.89	73.4	2.08	52.8
750HF SS 2" X 2"	2	-	2 1/2 - 12	2 - 11.5	1.781	45.0	*2 7/8	3.30	83.8	2.39	60.7

\*Not from Forging

"D" Dimension is minimum opening. Dimensions are for reference only, and are subject to change without notice.

**751 HF**  
**MALE RUN TEE**  
 S.A.E. 070424

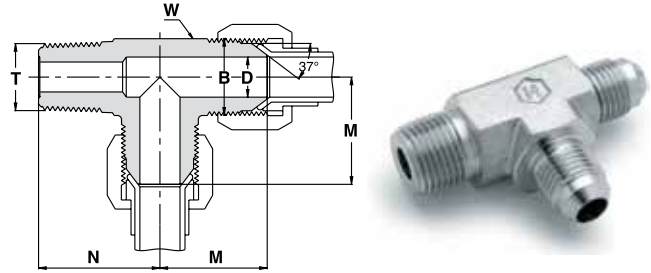

Ordering Information	Tube O.D.		B UN	T NPT	D		W Wrench Flat	M		N	
	inch	mm			inch	mm		inch	mm	inch	mm
751HF SS 1/8" X 1/8"	1/8	-	5/16 - 24	1/8 - 27	0.062	1.6	7/16	0.77	19.6	0.72	18.3
751HF SS 3/16" X 1/8"	3/16	-	3/8 - 24	1/8 - 27	0.125	3.2	1/2	0.83	21.1	0.72	18.3
751HF SS 1/4" / 6MM X 1/8"	1/4	6	7/16 - 20	1/8 - 27	0.172	4.4	1/2	0.89	22.6	0.78	19.8
751HF SS 1/4" / 6MM X 1/4"	1/4	6	7/16 - 20	1/4 - 18	0.172	4.4	5/8	1.06	26.9	1.09	27.7
751HF SS 5/16" / 8MM X 1/8"	5/16	8	1/2 - 20	1/8 - 27	0.190	4.8	5/8	0.95	24.1	0.78	19.8
751HF SS 5/16" / 8MM X 1/4"	5/16	8	1/2 - 20	1/4 - 18	0.234	6.0	5/8	1.06	26.9	1.09	27.7
751HF SS 3/8" / 10MM X 1/8"	3/8	10	9/16 - 18	1/8 - 27	0.190	4.8	5/8	1.06	26.9	0.90	22.8
751HF SS 3/8" / 10MM X 1/4"	3/8	10	9/16 - 18	1/4 - 18	0.280	7.1	5/8	1.06	26.9	1.09	27.7
751HF SS 3/8" / 10MM X 3/8"	3/8	10	9/16 - 18	3/8 - 18	0.297	7.5	13/16	1.14	29.0	1.22	31.0
751HF SS 3/8" / 10MM X 1/2"	3/8	10	9/16 - 18	1/2 - 14	0.297	7.5	15/16	1.23	31.2	1.47	37.3
751HF SS 1/2" / 12MM X 1/4"	1/2	12	3/4 - 16	1/4 - 18	0.280	7.1	15/16	1.25	31.8	1.22	31.0
751HF SS 1/2" / 12MM X 3/8"	1/2	12	3/4 - 16	3/8 - 18	0.380	9.5	15/16	1.25	31.8	1.22	31.0
751HF SS 1/2" / 12MM X 1/2"	1/2	12	3/4 - 16	1/2 - 14	0.391	9.9	15/16	1.33	33.7	1.47	37.3
751HF SS 1/2" / 12MM X 3/4"	1/2	12	3/4 - 16	3/4 - 14	0.391	9.9	1 1/8	1.42	36.0	1.59	40.4
751HF SS 5/8" / 16MM X 3/8"	5/8	16	7/8 - 14	3/8 - 18	0.380	9.5	15/16	1.45	36.8	1.30	33.0
751HF SS 5/8" / 16MM X 1/2"	5/8	16	7/8 - 14	1/2 - 14	0.470	11.9	15/16	1.45	36.8	1.47	37.3
751HF SS 5/8" / 16MM X 3/4"	5/8	16	7/8 - 14	3/4 - 14	0.484	12.3	1 1/8	1.53	38.9	1.59	40.4
751HF SS 3/4" / 18MM X 1/2"	3/4	18	1 1/16 - 12	1/2 - 14	0.470	11.9	1 1/8	1.66	41.0	1.59	40.4
751HF SS 3/4" / 18MM X 3/4"	3/4	18	1 1/16 - 12	3/4 - 14	0.609	15.5	1 1/8	1.66	41.0	1.59	40.4
751HF SS 7/8" / 20MM X 3/4"	7/8	20	1 3/16 - 12	3/4 - 14	0.719	18.3	1 3/8	1.73	43.9	1.69	42.9
751HF SS 1" / 25MM X 3/4"	1	25	1 5/16 - 12	3/4 - 14	0.719	18.3	1 3/8	1.81	46.0	1.78	45.2
751HF SS 1" / 25MM X 1"	1	25	1 5/16 - 12	1 - 11.5	0.844	21.5	1 3/8	1.81	46.0	1.97	50.0
751HF SS 1 1/4" / 32MM X 1"	1 1/4	32	1 5/8 - 12	1 - 11.5	0.844	21.5	*2	2.06	52.3	2.35	59.6
751HF SS 1 1/4" / 32MM X 1 1/4"	1 1/4	32	1 5/8 - 12	1 1/4 - 11.5	1.078	27.5	*2	2.06	52.3	2.38	60.5
751HF SS 1 1/2" / 38MM X 1 1/2"	1 1/2	38	1 7/8 - 12	1 1/2 - 11.5	1.312	33.0	*2	2.33	59.2	2.64	67.1
751HF SS 2" X 2"	2	-	2 1/2 - 12	2 - 11.5	1.781	45.0	*2 5/8	3.06	77.7	3.00	76.2

\*Not from Forging

"D" Dimension is minimum opening. Dimensions are for reference only, and are subject to change without notice.

**755 HF**  
**UNION ELBOW**  
 S.A.E. 070201

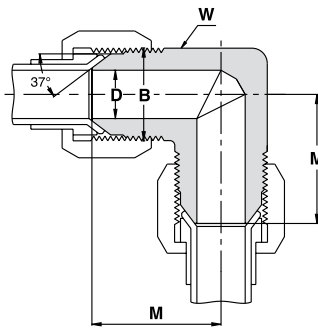

Ordering Information	Tube O.D.		B UN	D		W Wrench Flat	M	
	inch	mm		inch	mm		inch	inch
755HF SS 1/8"	1/8	-	5/16 - 24	0.062	1.6	7/16	0.77	19.6
755HF SS 3/16"	3/16	-	3/8 - 24	0.125	3.2	1/2	0.83	21.1
755HF SS 1/4" / 6MM	1/4	6	7/16 - 20	0.172	4.4	1/2	0.89	22.6
755HF SS 5/16" / 8MM	5/16	8	1/2 - 20	0.234	6.0	5/8	0.95	24.1
755HF SS 3/8" / 10MM	3/8	10	9/16 - 18	0.297	7.5	5/8	1.06	26.9
755HF SS 1/2" / 12MM	1/2	12	3/4 - 16	0.391	9.9	15/16	1.25	31.8
755HF SS 5/8" / 16MM	5/8	16	7/8 - 14	0.484	12.3	15/16	1.45	36.8
755HF SS 3/4" / 18MM	3/4	18	1 1/16 - 12	0.609	15.5	1 3/8	1.66	42.2
755HF SS 7/8" / 20MM	7/8	20	1 3/16 - 12	0.719	18.3	1 3/8	1.80	45.7
755HF SS 1" / 25MM	1	25	1 5/16 - 12	0.844	21.5	1 3/8	1.81	46.0
755HF SS 1 1/4" / 32MM	1 1/4	32	1 5/8 - 12	1.078	27.5	2	2.06	52.3
755HF SS 1 1/2" / 38MM	1 1/2	38	1 7/8 - 12	1.312	33.0	*2	2.33	59.2
755HF SS 2"	2	-	2 1/2 - 12	1.781	45.0	*2 5/8	3.06	77.7

\*Not from Forging

"D" Dimension is the minimum opening. Dimensions are for reference only, and are subject to change without



**771 HFL**  
**FEMALE RUN TEE**  
 S.A.E. 070426

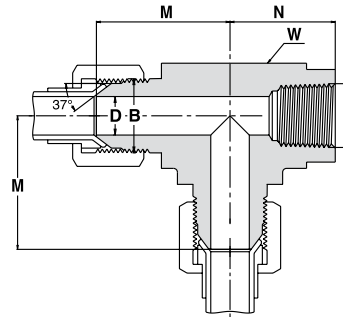

Ordering Information	TUBE O.D.		B UN	T NPT	D		W Wrench Flat	M		N	
	inch	mm			inch	mm		inch	mm	inch	mm
771HFL SS 1/8" X 1/8"	1/8	-	5/16 - 24	1/8 - 27	0.062	1.6	5/8	1.00	25.4	0.66	16.8
771HFL SS 3/16" X 1/8"	3/16	-	3/8 - 24	1/8 - 27	0.125	3.2	5/8	1.03	26.2	0.66	16.8
771HFL SS 1/4" / 6MM X 1/8"	1/4	6	7/16 - 20	1/8 - 27	0.172	4.4	5/8	1.08	27.4	0.66	16.8
771HFL SS 1/4" / 6MM X 1/4"	1/4	6	7/16 - 20	1/4 - 18	0.172	4.4	13/16	1.22	30.9	0.88	22.4
771HFL SS 5/16" / 8MM X 1/8"	5/16	8	1/2 - 20	1/8 - 27	0.234	6.0	5/8	1.08	27.4	0.66	16.8
771HFL SS 5/16" / 8MM X 1/4"	5/16	8	1/2 - 20	1/4 - 18	0.234	6.0	13/16	1.22	30.9	0.88	22.4
771HFL SS 3/8" / 10MM X 1/8"	3/8	10	9/16 - 18	1/8 - 27	0.297	7.5	5/8	1.06	26.9	0.66	16.8
771HFL SS 3/8" / 10MM X 1/4"	3/8	10	9/16 - 18	1/4 - 18	0.297	7.5	13/16	1.23	31.2	0.88	22.4
771HFL SS 3/8" / 10MM X 3/8"	3/8	10	9/16 - 18	3/8 - 18	0.297	7.5	15/16	1.31	33.2	1.02	25.9
771HFL SS 1/2" / 12MM X 1/4"	1/2	12	3/4 - 16	1/4 - 18	0.391	9.9	13/16	1.25	31.6	0.88	22.4
771HFL SS 1/2" / 12MM X 3/8"	1/2	12	3/4 - 16	3/8 - 18	0.391	9.9	15/16	1.42	36.1	1.02	25.9
771HFL SS 1/2" / 12MM X 1/2"	1/2	12	3/4 - 16	1/2 - 14	0.391	9.9	1 1/8	1.42	36.1	1.23	31.2
771HFL SS 5/8" / 16MM X 1/2"	5/8	16	7/8 - 14	1/2 - 14	0.484	12.3	1 1/8	1.64	41.5	1.23	31.2
771HFL SS 3/4" / 18MM X 1/2"	3/4	18	1 1/16 - 12	1/2 - 14	0.609	15.5	1 3/8	1.66	42.1	1.23	31.2
771HFL SS 3/4" / 18MM X 3/4"	3/4	18	1 1/16 - 12	3/4 - 14	0.609	15.5	1 3/8	1.89	48.0	1.36	34.5
771HFL SS 7/8" / 20MM X 3/4"	7/8	20	1 3/16 - 12	3/4 - 14	0.719	18.3	1 3/8	1.86	47.2	1.42	36.1
771HFL SS 1" / 25MM X 1"	1	25	1 5/16 - 12	1 - 11.5	0.844	21.5	*1 5/8	2.17	55.1	1.62	41.1
771HFL SS 1 1/4" / 32MM X 1 1/4"	1 1/4	32	1 5/8 - 12	1 1/4 - 11.5	1.078	27.5	*2 1/8	2.33	59.2	1.70	43.2
771HFL SS 1 1/2" / 38MM X 1 1/2"	1 1/2	38	1 7/8 - 12	1 1/2 - 11.5	1.312	33.0	*2 3/8	2.89	73.4	2.08	52.8
771HFL SS 2" X 2"	2	-	2 1/2 - 12	2 - 11.5	1.781	45.0	*2 7/8	3.30	83.8	2.39	60.7

\*Not from Forging

"D" Dimension is the minimum opening. Dimensions are for reference only, and are subject to change without

**772 HFL****FEMALE BRANCH TEE**

S.A.E. 070427

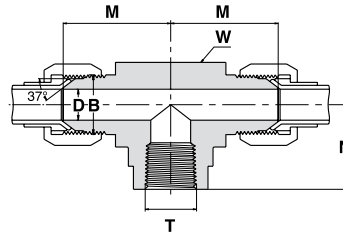

Ordering Information	Tube O.D.		B UN	T NPT	D		W Wrench Flat	M		N	
	inch	mm			inch	mm		inch	mm	inch	mm
772HFL SS 1/8" X 1/8"	1/8	-	5/16 - 24	1/8 - 27	0.062	1.6	5/8	1.00	25.4	0.66	16.8
772HFL SS 3/16" X 1/8"	3/16	-	3/8 - 24	1/8 - 27	0.125	3.2	5/8	1.03	26.2	0.66	16.8
772HFL SS 1/4" / 6MM X 1/8"	1/4	6	7/16 - 20	1/8 - 27	0.172	4.4	5/8	1.08	27.4	0.66	16.8
772HFL SS 1/4" / 6MM X 1/4"	1/4	6	7/16 - 20	1/4 - 18	0.172	4.4	13/16	1.22	30.9	0.88	22.4
772HFL SS 5/16" / 8MM X 1/8"	5/16	8	1/2 - 20	1/8 - 27	0.234	6.0	5/8	1.08	27.4	0.66	16.8
772HFL SS 5/16" / 8MM X 1/4"	5/16	8	1/2 - 20	1/4 - 18	0.234	6.0	13/16	1.22	30.9	0.88	22.4
772HFL SS 3/8" / 10MM X 1/8"	3/8	10	9/16 - 18	1/8 - 27	0.297	7.5	5/8	1.06	26.9	0.66	16.8
772HFL SS 3/8" / 10MM X 1/4"	3/8	10	9/16 - 18	1/4 - 18	0.297	7.5	13/16	1.23	31.2	0.88	22.4
772HFL SS 3/8" / 10MM X 3/8"	3/8	10	9/16 - 18	3/8 - 18	0.297	7.5	15/16	1.31	33.2	1.02	25.9
772HFL SS 1/2" / 12MM X 1/4"	1/2	12	3/4 - 16	1/4 - 18	0.391	9.9	13/16	1.25	31.6	0.88	22.4
772HFL SS 1/2" / 12MM X 3/8"	1/2	12	3/4 - 16	3/8 - 18	0.391	9.9	15/16	1.42	36.1	1.02	25.9
772HFL SS 1/2" / 12MM X 1/2"	1/2	12	3/4 - 16	1/2 - 14	0.391	9.9	1 1/8	1.42	36.1	1.23	31.2
772HFL SS 5/8" / 16MM X 1/2"	5/8	16	7/8 - 14	1/2 - 14	0.484	12.3	1 1/8	1.64	41.5	1.23	31.2
772HFL SS 3/4" / 18MM X 1/2"	3/4	18	1 1/16 - 12	1/2 - 14	0.609	15.5	1 3/8	1.66	42.1	1.23	31.2
772HFL SS 3/4" / 18MM X 3/4"	3/4	18	1 1/16 - 12	3/4 - 14	0.609	15.5	1 3/8	1.89	48.0	1.36	34.5
772HFL SS 7/8" / 20MM X 3/4"	7/8	20	1 3/16 - 12	3/4 - 14	0.719	18.3	1 3/8	1.86	47.2	1.42	36.1
772HFL SS 1" / 25MM X 1"	1	25	1 5/16 - 12	1 - 11.5	0.844	21.5	*1 5/8	2.17	55.1	1.62	41.1
772HFL SS 1 1/4" / 32MM X 1 1/4"	1 1/4	32	1 5/8 - 12	1 1/4 - 11.5	1.078	27.5	*2 1/8	2.33	59.2	1.70	43.2
772HFL SS 1 1/2" / 38MM X 1 1/2"	1 1/2	38	1 7/8 - 12	1 1/2 - 11.5	1.312	33.0	*2 3/8	2.89	73.4	2.08	52.8
772HFL SS 2" X 2"	2	-	2 1/2 - 12	2 - 11.5	1.781	45.0	*2 7/8	3.30	83.8	2.39	60.7

\*Not from Forging

"D" Dimension is the minimum opening. Dimensions are for reference only, and are subject to change without

**774 HFL**  
**BULKHEAD UNION**  
 S.A.E. 070601

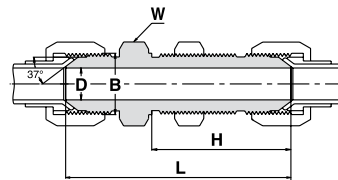

Ordering Information	Tube O.D.		B UN	D		W Hex. Flat	H		L	
	inch	mm		inch	mm		inch	mm	inch	mm
774HFL SS 3/16"	3/16	-	3/8 - 24	0.125	3.2	5/8	1.11	28.2	1.90	48.3
774HFL SS 1/4" / 6MM	1/4	6	7/16 - 20	0.172	4.4	11/16	1.20	30.5	2.07	52.6
774HFL SS 5/16" / 8MM	5/16	8	1/2 - 20	0.234	6.0	3/4	1.20	30.5	2.07	52.6
774HFL SS 3/8" / 10MM	3/8	10	9/16 - 18	0.297	7.5	13/16	1.28	32.5	2.18	55.4
774HFL SS 1/2" / 12MM	1/2	12	3/4 - 16	0.391	9.9	1	1.44	36.6	2.44	62.0
774HFL SS 5/8" / 16MM	5/8	16	7/8 - 14	0.484	12.3	1 1/8	1.58	40.1	2.74	69.6
774HFL SS 3/4" / 18MM	3/4	18	1 1/16 - 12	0.609	15.5	1 3/8	1.75	44.4	3.09	78.5
774HFL SS 7/8" / 20MM	7/8	20	1 3/16 - 12	0.719	18.3	1 1/2	1.75	44.4	3.12	79.2
774HFL SS 1" / 25MM	1	25	1 5/16 - 12	0.844	21.5	1 5/8	1.75	44.4	3.14	79.8
774HFL SS 1 1/4" / 32MM	1 1/4	32	1 5/8 - 12	1.078	27.5	1 7/8	1.80	45.7	3.31	84.1
774HFL SS 1 1/2" / 38MM	1 1/2	38	1 7/8 - 12	1.312	33.0	2 1/8	1.81	46.0	3.52	89.4
774HFL SS 2"	2	-	2 1/2 - 12	1.781	45.0	2 3/4	2.09	53.1	4.20	106.7

**774 HFLN**  
**BULKHEAD LOCKNUT**  
 S.A.E. 070118

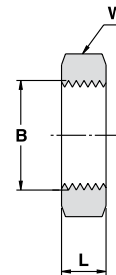

Ordering Information	Tube O.D.	B UNF	W Hex. Flat	L	
	inch		inch	inch	mm
774HFLN SS 3/16"	3/16	3/8 - 24	5/8	0.22	5.6
774HFLN SS 1/4" / 6MM	1/4	7/16 - 20	11/16	0.25	6.4
774HFLN SS 5/16" / 8MM	5/16	1/2 - 20	3/4	0.25	6.4
774HFLN SS 3/8" / 10MM	3/8	9/16 - 18	13/16	0.27	6.9
774HFLN SS 1/2" / 12MM	1/2	3/4 - 16	1	0.31	7.9
774HFLN SS 5/8" / 16MM	5/8	7/8 - 14	1 1/8	0.36	9.1
774HFLN SS 3/4" / 18MM	3/4	1 1/16 - 12	1 3/8	0.41	10.4
774HFLN SS 7/8" / 20MM	7/8	1 3/16 - 12	1 1/2	0.41	10.4
774HFLN SS 1" / 25MM	1	1 5/16 - 12	1 5/8	0.41	10.4
774HFLN SS 1 1/4" / 32MM	1 1/4	1 5/8 - 12	1 7/8	0.41	10.4
774HFLN SS 1 1/2" / 38MM	1 1/2	1 7/8 - 12	2 1/8	0.41	10.4
774HFLN SS 2"	2	1 1/2 - 12	2 3/4	0.41	10.4

"D" Dimension is the minimum opening. Dimensions are for reference only, and are subject to change without

**7102 HFL**  
**CROSS**  
 S.A.E. 070501

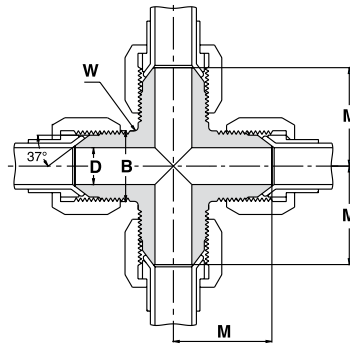

Ordering Information	Tube O.D.		B UN	D		W Wrench Flat	M	
	inch	mm		inch	mm		inch	inch
7102HFL SS 1/8"	1/8	-	5/16 - 24	0.062	1.6	7/16	0.77	19.6
7102HFL SS 3/16"	3/16	-	3/8 - 24	0.125	3.2	1/2	0.83	21.1
7102HFL SS 1/4" / 6MM	1/4	6	7/16 - 20	0.172	4.4	1/2	0.89	22.6
7102HFL SS 5/16" / 8MM	5/16	8	1/2 - 20	0.234	6.0	5/8	0.95	24.1
7102HFL SS 3/8" / 10MM	3/8	10	9/16 - 18	0.297	7.5	5/8	1.06	26.9
7102HFL SS 1/2" / 12MM	1/2	12	3/4 - 16	0.391	9.9	13/16	1.25	31.8
7102HFL SS 5/8" / 16MM	5/8	16	7/8 - 14	0.484	12.3	*15/16	1.45	36.8
7102HFL SS 3/4" / 18MM	3/4	18	1 1/16 - 12	0.609	15.5	*1 1/8	1.66	42.2
7102HFL SS 7/8" / 20MM	7/8	20	1 3/16 - 12	0.719	18.3	*1 3/8	1.80	45.7
7102HFL SS 1" / 25MM	1	25	1 5/16 - 12	0.844	21.5	*1 3/8	1.81	46.0
7102HFL SS 1 1/4" / 32MM	1 1/4	32	1 5/8 - 12	1.078	27.5	*1 11/16	2.06	51.0
7102HFL SS 1 1/2" / 38MM	1 1/2	38	1 7/8 - 12	1.312	33.0	*2	2.33	59.2
7102HFL SS 2"	2	-	2 1/2 - 12	1.781	45.0	*2 5/8	3.06	77.7

\*Not from Forging

"D" Dimension is the minimum opening. Dimensions are for reference only, and are subject to change without

**7639 HF**  
**TUBE PLUG**  
 S.A.E. 070109

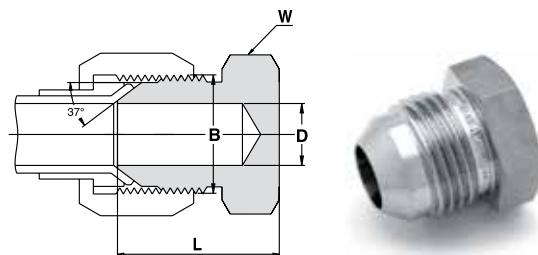

Ordering Information	Tube O.D.		B UN	D		W Hex. Flat	L	
	inch	mm		inch	mm		inch	mm
7639HF SS 1/8"	1/8	-	5/16 - 24	0.062	1.6	7/16	0.70	17.8
7639HF SS 3/16"	3/16	-	3/8 - 24	0.125	3.2	7/16	0.73	18.5
7639HF SS 1/4" / 6MM	1/4	6	7/16 - 20	0.172	4.4	1/2	0.80	20.3
7639HF SS 5/16" / 8MM	5/16	8	1/2 - 20	0.234	6.0	9/16	0.80	20.3
7639HF SS 3/8" / 10MM	3/8	10	9/16 - 18	0.297	7.5	5/8	0.84	21.3
7639HF SS 1/2" / 12MM	1/2	12	3/4 - 16	0.391	9.9	13/16	0.94	23.9
7639HF SS 5/8" / 16MM	5/8	16	7/8 - 14	0.484	12.3	15/16	1.10	27.9
7639HF SS 3/4" / 18MM	3/4	18	1 1/16 - 12	0.609	15.5	1 1/8	1.28	32.5
7639HF SS 7/8" / 20MM	7/8	20	1 3/16 - 12	0.719	18.3	1 1/4	1.31	33.3
7639HF SS 1" / 25MM	1	25	1 5/16 - 12	0.844	21.5	1 3/8	1.33	33.8
7639HF SS 1 1/4" / 32MM	1 1/4	32	1 5/8 - 12	1.078	27.5	1 11/16	1.45	36.8
7639HF SS 1 1/2" / 38MM	1 1/2	38	1 7/8 - 12	1.312	33.0	2	1.65	41.9
7639HF SS 2"	2	-	2 1/2 - 12	1.781	45.0	2 5/8	2.05	52.1

**7640 HF**  
**CAP**  
 S.A.E. 070112

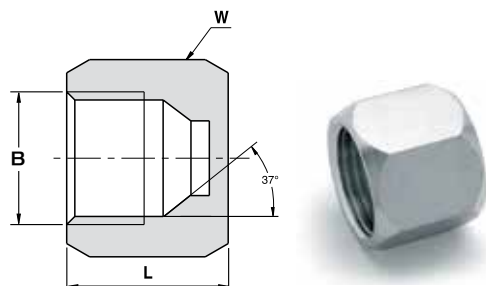

Ordering Information	TUBE O.D.		B UN	W Hex. Flat		L	
	inch	mm		inch	inch	mm	
7640HF SS 1/8"	1/8	-	5/16 - 24	3/8	0.550	12.7	
7640HF SS 3/16"	3/16	-	3/8 - 24	7/16	0.562	14.3	
7640HF SS 1/4" / 6MM	1/4	6	7/16 - 20	9/16	0.594	15.1	
7640HF SS 5/16" / 8MM	5/16	8	1/2 - 20	5/8	0.609	15.5	
7640HF SS 3/8" / 10MM	3/8	10	9/16 - 18	11/16	0.625	15.9	
7640HF SS 1/2" / 12MM	1/2	12	3/4 - 16	7/8	0.750	19.0	
7640HF SS 5/8" / 16MM	5/8	16	7/8 - 14	1	0.844	21.4	
7640HF SS 3/4" / 18MM	3/4	18	1 1/16 - 12	1 1/4	0.906	23.0	
7640HF SS 7/8" / 20MM	7/8	20	1 3/16 - 12	1 3/8	0.969	24.6	
7640HF SS 1" / 25MM	1	25	1 5/16 - 12	1 1/2	1.016	25.8	
7640HF SS 1 1/4" / 32MM	1 1/4	32	1 5/8 - 12	2	1.062	27.0	
7640HF SS 1 1/2" / 38MM	1 1/2	38	1 7/8 - 12	2 1/4	1.188	30.2	
7640HF SS 2"	2	-	1 1/2 - 12	2 7/8	1.438	36.5	

"D" Dimension is the minimum opening. Dimensions are for reference only, and are subject to change without

