

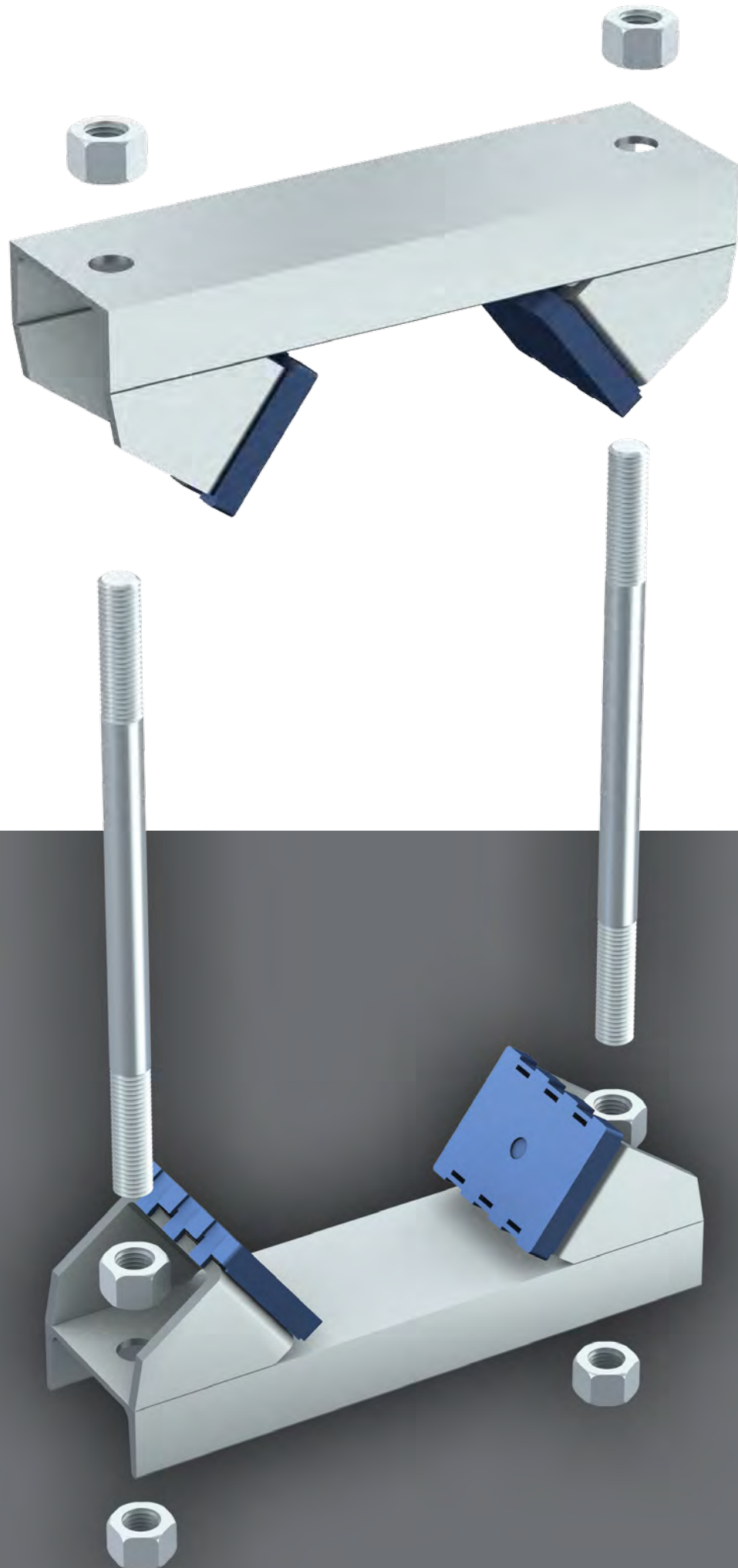

PIPE CLAMPS **SUPER HEAVYWEIGHT SERIES**  
Order Codes and Dimensions (mm/in)

PIPE CLAMPS  
**SUPER HEAVYWEIGHT SERIES**

116





# PIPE CLAMPS **SUPER HEAVYWEIGHT SERIES**

## CLAMP BODY STANDARD MATERIALS



**Carbon Steel S 275 JR**  
Electro-welded clamp with U profile NP 140  
Finishing Zinc Plated Fe Zn c8 II

**DIFFERENT DAMETERS AND MATERIALS AVAILABLE ON REQUEST.**

For Material Characteristics, see Technical Appendix (page 143).

## COMPONENTS AND ACCESSORIES STANDARD MATERIALS

**Steel brace** in Carbon Steel C45  
Surface finishing Zinc Plated Fe Zn c8 II

**Nut M30**  
Surface finishing Zinc Plated

**Plastic pads** in Polypropylene

**Elongated plate PL inserts on request**  
CarbonSteel S 275 JR

For Material Characteristics, see Technical Appendix (page 143).





# PIPE CLAMPS SUPER HEAVYWEIGHT SERIES

Order Codes and Dimensions (mm/in)

## SSP ELECTRO- WELDED CLAMP BODY

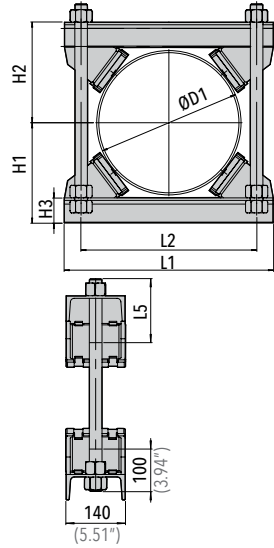
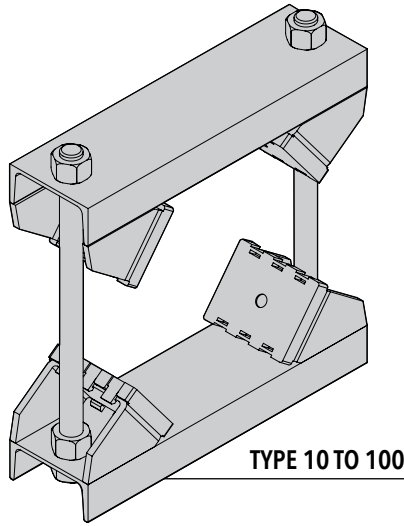

**ORDER EXAMPLE**  
SSP10

Code	ØD1 Outside Diameter	L1	L2	H1	H2	H3	Steel Brace M30	L5
SSP10	166÷220 (6.53"÷8.66")	405 (15.94")	300 (11.81")	210 (8.26")	210 (8.26")	60 (2.36")	420 (16.54")	120 (4.72")
SSP20	221÷275 (8.70"÷10.85")	440 (17.32")	334 (13.15")	220 (8.66")	220 (8.66")	60 (2.36")	450 (17.72")	150 (5.90")
SSP30	276÷325 (10.87"÷12.80")	460 (18.11")	375 (14.76")	245 (9.64")	245 (9.64")	60 (2.36")	510 (20.08")	198 (7.79")
SSP40	326÷370 (12.83"÷14.57")	500 (19.68")	420 (16.53")	270 (10.63")	270 (10.63")	60 (2.36")	550 (21.65")	150 (5.90")
SSP50	371÷425 (14.61"÷16.73")	560 (22.04")	475 (18.70")	300 (11.81")	300 (11.81")	60 (2.36")	620 (24.41")	198 (7.79")
SSP60	426÷480 (16.77"÷18.9")	620 (24.41")	535 (21.06")	325 (12.80")	325 (12.80")	60 (2.36")	680 (26.77")	180 (7.08")
SSP70	481÷550 (18.93"÷21.65")	700 (27.56")	605 (23.81")	360 (14.17")	360 (14.17")	60 (2.36")	730 (28.74")	198 (7.79")
SSP80	551÷630 (21.69"÷24.80")	760 (29.92")	670 (26.37")	410 (16.14")	410 (16.14")	60 (2.36")	800 (31.50")	198 (7.79")
SSP90	631÷715 (24.84"÷28.15")	845 (33.46")	755 (29.72")	452 (17.80")	452 (17.80")	60 (2.36")	884 (34.80")	280 (11.02")
SSP100	716÷800 (28.19"÷31.50")	940 (37")	850 (33.46")	495 (19.49")	495 (19.49")	60 (2.36")	970 (38.19")	170 (6.69")

Code SSP CD (Material Carbon Steel S 275 JR)

Nut: M30 | N. of Nuts: 6 | N. of Plastic Pads: 4



# SSP PL ELECTRO- WELDED CLAMP BODY

WITH ELONGATED PLATE

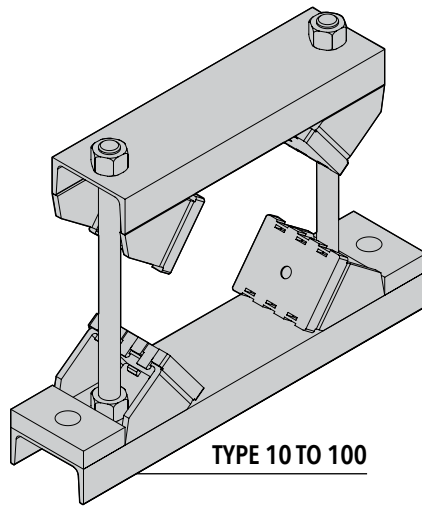

TYPE 10 TO 100

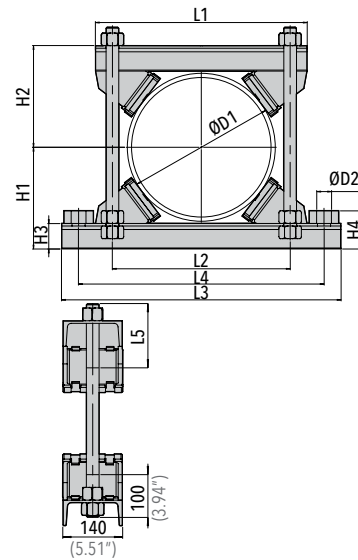

Code	ØD1 Outside Diameter	L1	L2	L3	L4	H1	H2	H3	H4	ØD2	Steel Brace M30	L5
SSP10 PL	166÷220 (6.53"÷8.66")	405 (15.94")	300 (11.81")	565 (22.24")	460 (18.11")	210 (8.26")	210 (8.26")	60 (2.36")	90 (3.54")	31 (1.22")	420 (16.54")	120 (4.72")
SSP20 PL	221÷275 (8.70"÷10.85")	440 (17.32")	334 (13.15")	600 (23.62")	494 (19.44")	220 (8.66")	220 (8.66")	60 (2.36")	90 (3.54")	31 (1.22")	450 (17.72")	150 (5.90")
SSP30 PL	276÷325 (10.87"÷12.80")	460 (18.11")	375 (14.76")	620 (24.41")	535 (21.06")	245 (9.64")	245 (9.64")	60 (2.36")	90 (3.54")	31 (1.22")	510 (20.08")	198 (7.79")
SSP40 PL	326÷370 (12.83"÷14.57")	500 (19.68")	420 (16.53")	660 (25.98")	580 (22.83")	270 (10.63")	270 (10.63")	60 (2.36")	90 (3.54")	31 (1.22")	550 (21.65")	150 (5.90")
SSP50 PL	371÷425 (14.61"÷16.73")	560 (22.04")	475 (18.70")	720 (28.34")	635 (25")	300 (11.81")	300 (11.81")	60 (2.36")	90 (3.54")	31 (1.22")	620 (24.41")	198 (7.79")
SSP60 PL	426÷480 (16.77"÷18.9")	620 (24.41")	535 (21.06")	800 (31.50")	735 (28.93")	325 (12.80")	325 (12.80")	60 (2.36")	90 (3.54")	31 (1.22")	680 (26.77")	180 (7.08")
SSP70 PL	481÷550 (18.93"÷21.65")	700 (27.56")	605 (23.81")	880 (34.64")	805 (31.69")	360 (14.17")	360 (14.17")	60 (2.36")	90 (3.54")	31 (1.22")	730 (28.74")	198 (7.79")
SSP80 PL	551÷630 (21.69"÷24.80")	760 (29.92")	670 (26.37")	940 (37")	870 (34.25")	410 (16.14")	410 (16.14")	60 (2.36")	90 (3.54")	31 (1.22")	800 (31.50")	198 (7.79")
SSP90 PL	631÷715 (24.84"÷28.15")	845 (33.46")	755 (29.72")	1025 (40.31")	955 (37.6")	452 (17.80")	452 (17.80")	60 (2.36")	90 (3.54")	31 (1.22")	884 (34.80")	280 (11.02")
SSP100 PL	716÷800 (28.19"÷31.50")	940 (37")	850 (33.46")	1120 (44.09")	1050 (41.33")	495 (19.49")	495 (19.49")	60 (2.36")	90 (3.54")	31 (1.22")	970 (38.19")	170 (6.69")

SUPER HEAVYWEIGHT SERIES  
PIPE CLAMPS



# SSP CD ELECTRO- WELDED CLAMP BODY

TWO FLANKED CLAMPS

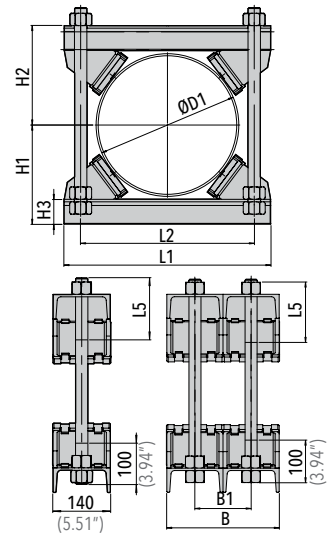
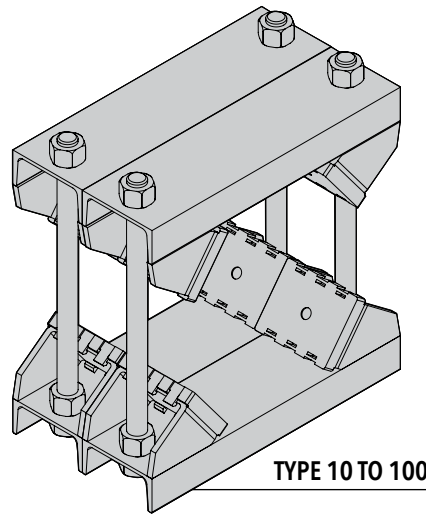

Code	ØD1 Outside Diameter	L1	L2	H1	H2	H3	B	B1	Steel Brace M30	L5
SSP10 CD	166÷220 (6.53"÷8.66")	405 (15.94")	300 (11.81")	210 (8.26")	210 (8.26")	60 (2.36")	290 (11.42")	150 (5.90")	420 (16.54")	120 (4.72")
SSP20 CD	221÷275 (8.70"÷10.85")	440 (17.32")	334 (13.15")	220 (8.66")	220 (8.66")	60 (2.36")	290 (11.42")	150 (5.90")	450 (17.72")	150 (5.90")
SSP30 CD	276÷325 (10.87"÷12.80")	460 (18.11")	375 (14.76")	245 (9.64")	245 (9.64")	60 (2.36")	290 (11.42")	150 (5.90")	510 (20.08")	198 (7.79")
SSP40 CD	326÷370 (12.83"÷14.57")	500 (19.68")	420 (16.53")	270 (10.63")	270 (10.63")	60 (2.36")	290 (11.42")	150 (5.90")	550 (21.65")	150 (5.90")
SSP50 CD	371÷425 (14.61"÷16.73")	560 (22.04")	475 (18.70")	300 (11.81")	300 (11.81")	60 (2.36")	290 (11.42")	150 (5.90")	620 (24.41")	198 (7.79")
SSP60 CD	426÷480 (16.77"÷18.9")	620 (24.41")	535 (21.06")	325 (12.80")	325 (12.80")	60 (2.36")	290 (11.42")	150 (5.90")	680 (26.77")	180 (7.08")
SSP70 CD	481÷550 (18.93"÷21.65")	700 (27.56")	605 (23.81")	360 (14.17")	360 (14.17")	60 (2.36")	290 (11.42")	150 (5.90")	730 (28.74")	198 (7.79")
SSP80 CD	551÷630 (21.69"÷24.80")	760 (29.92")	670 (26.37")	410 (16.14")	410 (16.14")	60 (2.36")	290 (11.42")	150 (5.90")	800 (31.50")	198 (7.79")
SSP90 CD	631÷715 (24.84"÷28.15")	845 (33.46")	755 (29.72")	452 (17.80")	452 (17.80")	60 (2.36")	290 (11.42")	150 (5.90")	884 (34.80")	280 (11.02")
SSP100 CD	716÷800 (28.19"÷31.50")	940 (37")	850 (33.46")	495 (19.49")	495 (19.49")	60 (2.36")	290 (11.42")	150 (5.90")	970 (38.19")	170 (6.69")

Code SSP CD (Material Carbon Steel S 275 JR)

Nut: M30 | N. of Nuts: 12 | N. of Plastic Pads: 8



# SSP PL CD ELECTRO- WELDED CLAMP BODY

TWO FLANKED CLAMPS  
WITH ELONGATED PLATE

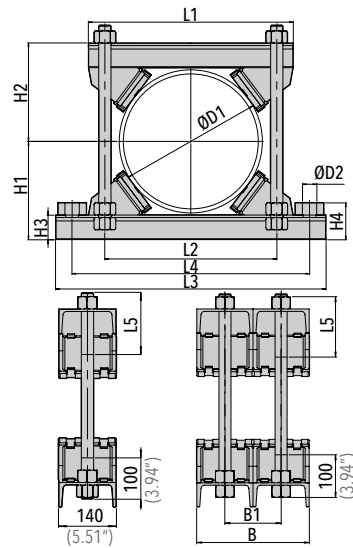
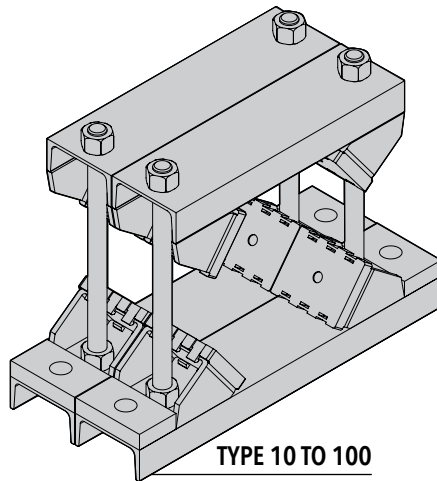

**SUPER HEAVYWEIGHT SERIES**  
PIPE CLAMPS

Code	ØD1 Outside Diameter	L1	L2	L3	L4	H1	H2	H3	H4	B	B1	ØD2	Steel Brace M30	L5
SSP10 PL CD	166÷220 (6.53"÷8.66")	405 (15.94")	300 (11.81")	565 (22.24")	460 (18.11")	210 (8.26")	210 (8.26")	60 (2.36")	90 (3.54")	290 (11.42")	150 (5.90")	31 (1.22")	420 (16.54")	120 (4.72")
SSP20 PL CD	221÷275 (8.70"÷10.85")	440 (17.32")	334 (13.15")	600 (23.62")	494 (19.44")	220 (8.66")	220 (8.66")	60 (2.36")	90 (3.54")	290 (11.42")	150 (5.90")	31 (1.22")	450 (17.72")	150 (5.90")
SSP30 PL CD	276÷325 (10.87"÷12.80")	460 (18.11")	375 (14.76")	620 (24.41")	535 (21.06")	245 (9.64")	245 (9.64")	60 (2.36")	90 (3.54")	290 (11.42")	150 (5.90")	31 (1.22")	510 (20.08")	198 (7.79")
SSP40 PL CD	326÷370 (12.83"÷14.57")	500 (19.68")	420 (16.53")	660 (25.98")	580 (22.83")	270 (10.63")	270 (10.63")	60 (2.36")	90 (3.54")	290 (11.42")	150 (5.90")	31 (1.22")	550 (21.65")	150 (5.90")
SSP50 PL CD	371÷425 (14.61"÷16.73")	560 (22.04")	475 (18.70")	720 (28.34")	635 (25")	300 (11.81")	300 (11.81")	60 (2.36")	90 (3.54")	290 (11.42")	150 (5.90")	31 (1.22")	620 (24.41")	198 (7.79")
SSP60 PL CD	426÷480 (16.77"÷18.9")	620 (24.41")	535 (21.06")	800 (31.50")	735 (28.93")	325 (12.80")	325 (12.80")	60 (2.36")	90 (3.54")	290 (11.42")	150 (5.90")	31 (1.22")	680 (26.77")	180 (7.08")
SSP70 PL CD	481÷550 (18.93"÷21.65")	700 (27.56")	605 (23.81")	880 (34.64")	805 (31.69")	360 (14.17")	360 (14.17")	60 (2.36")	90 (3.54")	290 (11.42")	150 (5.90")	31 (1.22")	730 (28.74")	198 (7.79")
SSP80 PL CD	551÷630 (21.69"÷24.80")	760 (29.92")	670 (26.37")	940 (37")	870 (34.25")	410 (16.14")	410 (16.14")	60 (2.36")	90 (3.54")	290 (11.42")	150 (5.90")	31 (1.22")	800 (31.50")	198 (7.79")
SSP90 PL CD	631÷715 (24.84"÷28.15")	845 (33.46")	755 (29.72")	1025 (40.31")	955 (37.6")	452 (17.80")	452 (17.80")	60 (2.36")	90 (3.54")	290 (11.42")	150 (5.90")	31 (1.22")	884 (34.80")	280 (11.02")
SSP100 PL CD	716÷800 (28.19"÷31.50")	940 (37")	850 (33.46")	1120 (44.09")	1050 (41.33")	495 (19.49")	495 (19.49")	60 (2.36")	90 (3.54")	290 (11.42")	150 (5.90")	31 (1.22")	970 (38.19")	170 (6.69")

Code SSP (Material Carbon Steel S 275 JR)

Nut: M30 | N. of Nuts: 12 | N. of Plastic Pads: 8

