



PIPE CLAMPS **MULTI SERIES**

Order Codes and Dimensions (mm/in)

PIPE CLAMPS
MULTI SERIES

100

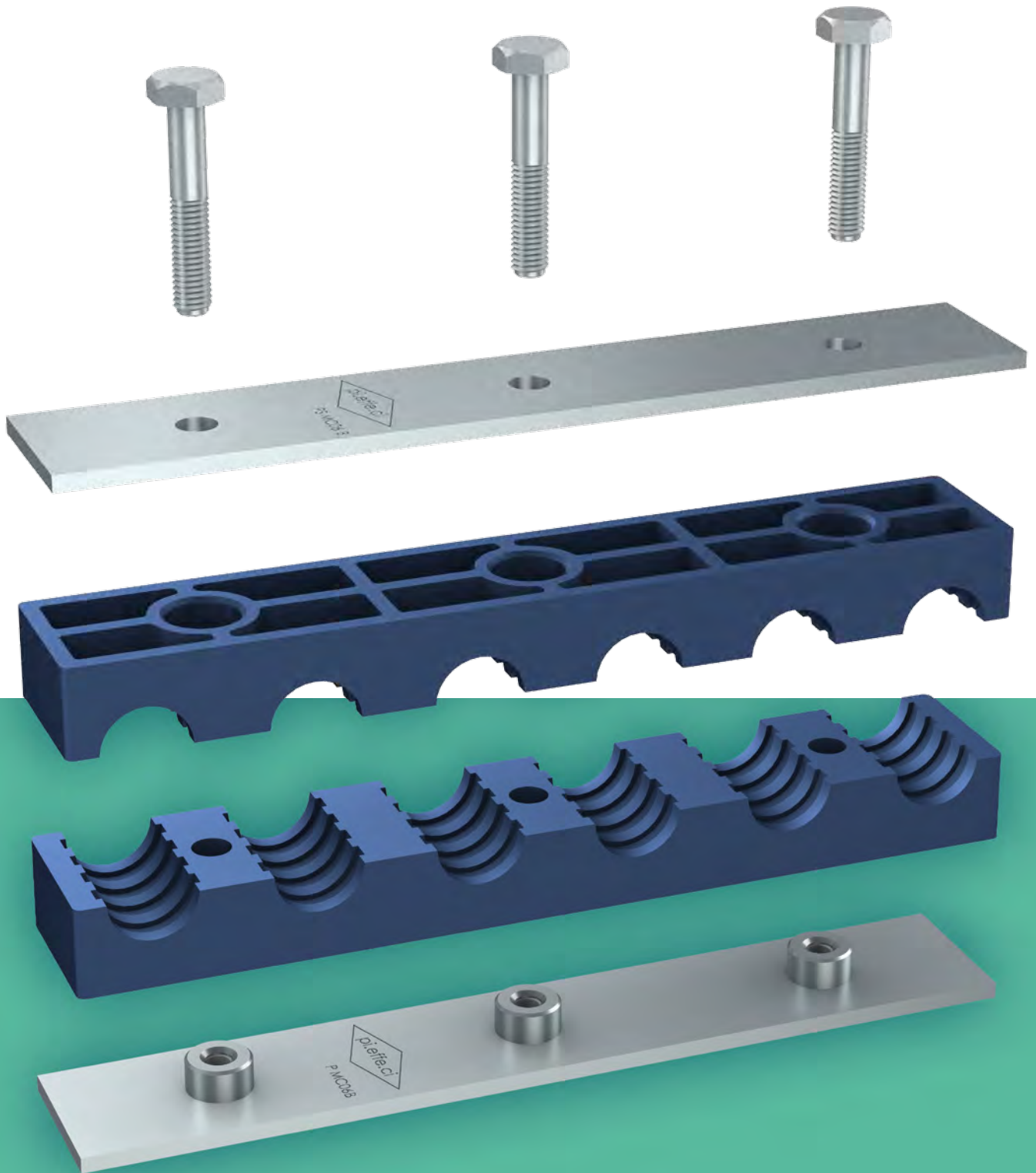

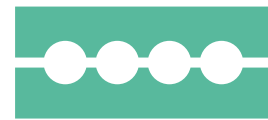

PIPE CLAMPS **MULTI SERIES**

101

CLAMP BODY STANDARD MATERIALS



Polypropylene
Colour **Blue**
Code **PP**

**OTHER COLOURS
AVAILABLE ON DEMAND!**



Polyamide
Colour **Black**
Code **PA**



Self-extinguishing Polypropylene
Colour **White**
Code **AU**

DIFFERENT DAMETERS AND MATERIALS AVAILABLE ON REQUEST.

ON REQUEST, ANY CLAMP BODY CAN BE SUPPLIED
WITH DIFFERENT DIAMETERS.

Clamp body internal surface **Profiled**.

For Material Characteristics, see Technical Appendix (page 143).

COMPONENTS AND ACCESSORIES STANDARD MATERIALS

Carbon Steel S 235 JR with finishing surface in white zinc-coated
Fe Zn c8 II.

Untreated are available on request.

Stainless Steel Inox 316L (X2 CrNiMo 17-12-2) 1.4404
marked with X identification code.

Metric thread: code **M**
UNC thread: code **UNC**.

For Material Characteristics, see Technical Appendix (page 143).





MC03 CLAMP BODY

FOR N. 3 PIPES

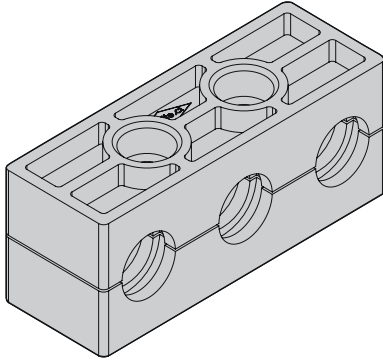

Code	Outside Diameter ØD		L1	L2	L3	B	H	S
	mm	nominal bore pipe in						
	6							
	6,4	1/4"						
MC03 A	8	5/16"	56 (2.20")	20 (.79")	20 (.79")	30 (1.18")	28 (1.10")	0,6 (.02")
	9,5	3/8"						
	10	1/8"						
	12							
	10	1/8"						
	12							
	12,7	1/2"						
	13,5	1/4"						
MC03 B	14		85 (3.34")	29 (1.14")	29 (1.14")	30 (1.18")	34 (1.34")	0,6 (.02")
	15							
	16	5/8"						
	17,2	3/8"						
	18							
	15							
	16	5/8"						
	17,2	3/8"						
	18							
MC03 C	20		106 (4.17")	36 (1.42")	36 (1.42")	30 (1.18")	38 (1.50")	0,8 (.03")
	21,3	1/2"						
	22	7/8"						
	23							
	25							
	25,4	1"						

PIPE CLAMPS
MULTI SERIES

102

Code MC03 (PP - PA - AU)

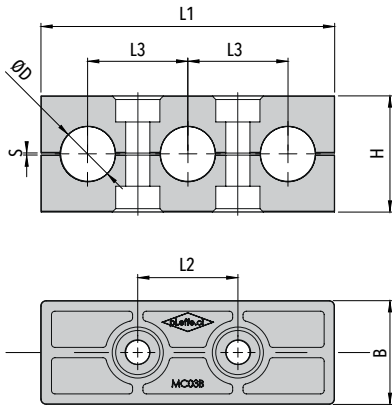

ORDER EXAMPLE

MC03 A - 12 - PP



PMC03 WELD PLATE

WITH N. 2 SCREWS

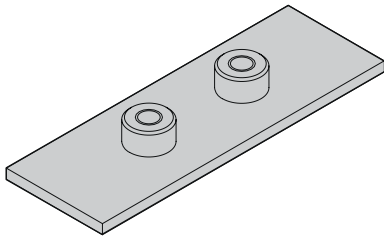
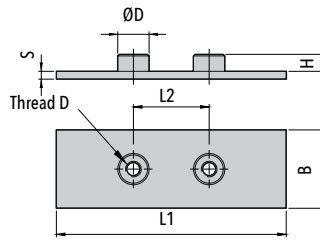

Code	Thread D	L1	L2	B	H	S	ØD
------	----------	----	----	---	---	---	----

PMC03 A XPMC03 A	M6 (1/4-20 UNC)	58 (2.28")	20 (.79")	30 (1.18")	6,5 (.26")	3 (.12")	12 (.47")
-----------------------------------	--------------------	---------------	--------------	---------------	---------------	-------------	--------------

PMC03 B XPMC03 B	M6 (1/4-20 UNC)	87 (3.43")	29 (1.14")	30 (1.18")	6,5 (.26")	3 (.12")	12 (.47")
-----------------------------------	--------------------	---------------	---------------	---------------	---------------	-------------	--------------

PMC03 C XPMC03 C	M6 (1/4-20 UNC)	108 (4.25")	36 (1.42")	30 (1.18")	6,5 (.26")	3 (.12")	12 (.47")
-----------------------------------	--------------------	----------------	---------------	---------------	---------------	-------------	--------------

Code **PMC03** (Carbon Steel S 235 JR)
Code **XPMC03** (Stainless Steel AISI 316L)

PSMC03 UPPER PLATE

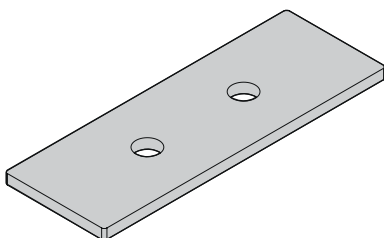
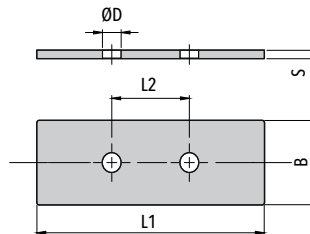

Code	L1	L2	B	S	ØD
------	----	----	---	---	----

PSMC03 A XPSMC03 A	56 (2.20")	20 (.79")	30 (1.18")	3 (.12")	7 (.27")
-------------------------------------	---------------	--------------	---------------	-------------	-------------

PSMC03 B XPSMC03 B	85 (3.34")	29 (1.14")	30 (1.18")	3 (.12")	7 (.27")
-------------------------------------	---------------	---------------	---------------	-------------	-------------

PSMC03 C XPSMC03 C	106 (4.17")	36 (1.42")	30 (1.18")	3 (.12")	7 (.27")
-------------------------------------	----------------	---------------	---------------	-------------	-------------

Code **PSMC03** (Carbon Steel S 235 JR)
Code **XPSMC03** (Stainless Steel AISI 316L)



MC04 CLAMP BODY

FOR N. 4 PIPES

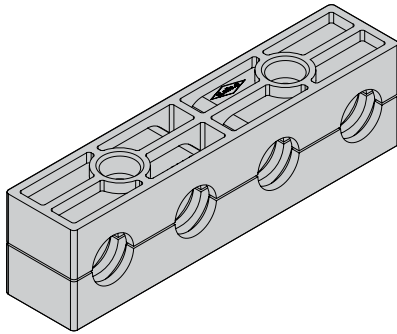

Code	Outside Diameter ØD		L1	L2	L3	B	H	S
	mm	nominal bore pipe in						
	6							
	6,4	1/4"						
MC04 A	8	5/16"	76 (4.56")	40 (1.57")	20 (.79")	30 (1.18")	28 (1.10")	0,6 (.02")
	9,5	3/8"						
	10	1/8"						
	12							
	10	1/8"						
	12							
	12,7	1/2"						
	13,5	1/4"						
MC04 B	14		114 (6.77")	58 (2.28")	29 (1.14")	30 (1.18")	34 (1.34")	0,6 (.02")
	15							
	16	5/8"						
	17,2	3/8"						
	18							
	15							
	16	5/8"						
	17,2	3/8"						
	18							
	19	3/4"						
MC04 C	20		142 (8.42")	72 (2.83")	36 (1.42")	30 (1.18")	38 (1.50")	0,8 (.03")
	21,3	1/2"						
	22	7/8"						
	23							
	25							
	25,4	1"						

PIPE CLAMPS
MULTI SERIES

104

Code MC04 (PP - PA - AU)

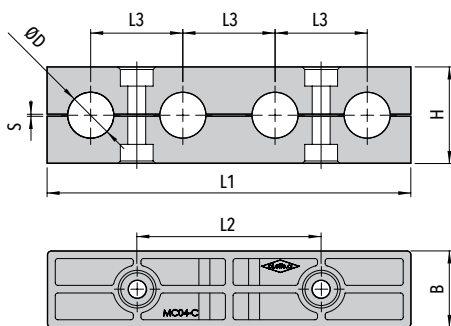

ORDER EXAMPLE

MC04 B - 16 - PP



PIPE CLAMPS MULTI SERIES

Order Codes and Dimensions (mm/in)

PMC04 WELD PLATE

WITH N. 2 SCREWS

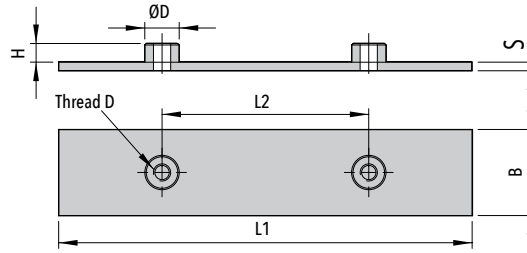

Code	Thread D	L1	L2	B	H	S	ØD
------	----------	----	----	---	---	---	----

PMC04 A XPMC04 A	M6 (1/4-20 UNC)	78 (4.72")	40 (1.57")	30 (1.18")	6,5 (.25")	3 (.12")	12 (.47")
---------------------	--------------------	---------------	---------------	---------------	---------------	-------------	--------------

PMC04 B XPMC04 B	M6 (1/4-20 UNC)	116 (6.85")	58 (2.28")	30 (1.18")	6,5 (.25")	3 (.12")	12 (.47")
---------------------	--------------------	----------------	---------------	---------------	---------------	-------------	--------------

PMC04 C XPMC04 C	M6 (1/4-20 UNC)	144 (8.50")	72 (2.83")	30 (1.18")	6,5 (.25")	3 (.12")	12 (.47")
---------------------	--------------------	----------------	---------------	---------------	---------------	-------------	--------------

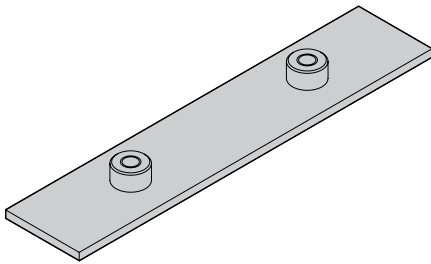

Code **PMC04** (Carbon Steel S 235 JR)
Code **XPMC04** (Stainless Steel AISI 316L)

PIPE CLAMPS
MULTI SERIES

PSMC04 UPPER PLATE

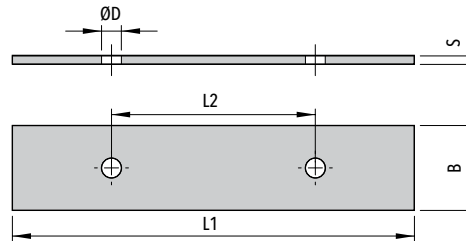

Code	L1	L2	B	S	ØD
------	----	----	---	---	----

PSMC04 A XPSMC04 A	76 (4.56")	40 (1.57")	30 (1.18")	3 (.12")	7 (.27")
-----------------------	---------------	---------------	---------------	-------------	-------------

PSMC04 B XPSMC04 B	114 (6.77")	58 (2.28")	30 (1.18")	3 (.12")	7 (.27")
-----------------------	----------------	---------------	---------------	-------------	-------------

PSMC04 C XPSMC04 C	142 (8.42")	72 (2.83")	30 (1.18")	3 (.12")	7 (.27")
-----------------------	----------------	---------------	---------------	-------------	-------------

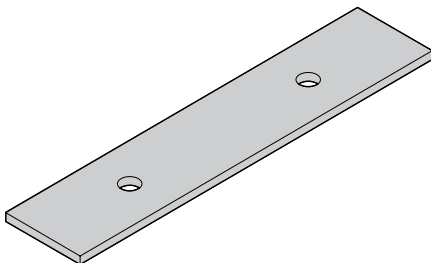

Code **PSMC04** (Carbon Steel S 235 JR)
Code **XPSMC04** (Stainless Steel AISI 316L)

105



MC06 CLAMP BODY

FOR N. 6 PIPES

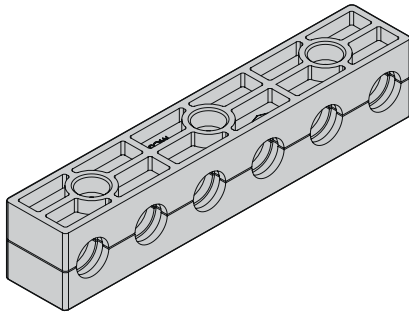

PIPE CLAMPS
MULTI SERIES

106

Code **MC06** (PP - PA - AU)

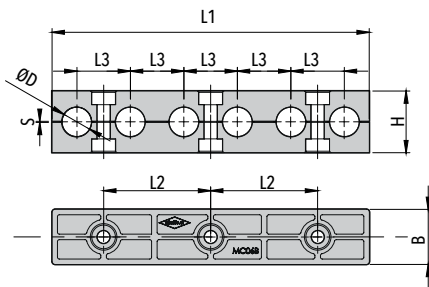

Code	Outside Diameter ØD		L1	L2	L3	B	H	S
	mm	nominal bore pipe in						
MC06 A	6							
	6,4	1/4"						
	8	5/16"	116 (4.56")	40 (1.57")	20 (.79")	30 (1.18")	28 (1.10")	0,6 (.02")
	9,5	3/8"						
	10	1/8"						
	12							
MC06 B	10	1/8"						
	12							
	12,7	1/2"						
	13,5	1/4"						
	14		172 (6.77")	58 (2.28")	29 (1.14")	30 (1.18")	34 (1.34")	0,6 (.02")
	15							
	16	5/8"						
	17,2	3/8"						
	18							
	15							
MC06 C	16	5/8"						
	17,2	3/8"						
	18							
	19	3/4"						
	20		214 (8.42")	72 (2.83")	36 (1.42")	30 (1.18")	38 (1.50")	0,8 (.03")
	21,3	1/2"						
	22	7/8"						
	23							
	25							
	25,4	1"						

ORDER EXAMPLE

MC06 C - 20 - PP



PIPE CLAMPS MULTI SERIES

Order Codes and Dimensions (mm/in)

PMC06 WELD PLATE

WITH N. 3 SCREWS

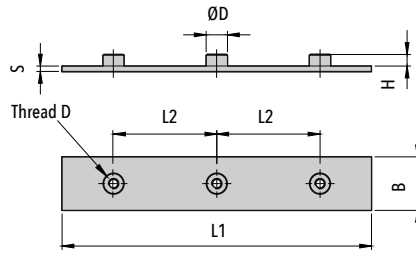

Code	Thread D	L1	L2	B	H	S	ØD
------	----------	----	----	---	---	---	----

PMC06 A XPMC06 A	M6 (1/4-20 UNC)	120 (4.72")	40 (1.57")	30 (1.18")	6,5 (.25")	3 (.12")	12 (.47")
-----------------------------------	--------------------	----------------	---------------	---------------	---------------	-------------	--------------

PMC06 B XPMC06 B	M6 (1/4-20 UNC)	174 (6.85")	58 (2.28")	30 (1.18")	6,5 (.25")	3 (.12")	12 (.47")
-----------------------------------	--------------------	----------------	---------------	---------------	---------------	-------------	--------------

PMC06 C XPMC06 C	M6 (1/4-20 UNC)	216 (8.50")	72 (2.83")	30 (1.18")	6,5 (.25")	3 (.12")	12 (.47")
-----------------------------------	--------------------	----------------	---------------	---------------	---------------	-------------	--------------

Code **PMC06** (Carbon Steel S 235 JR)
Code **XPMC06** (Stainless Steel AISI 316L)

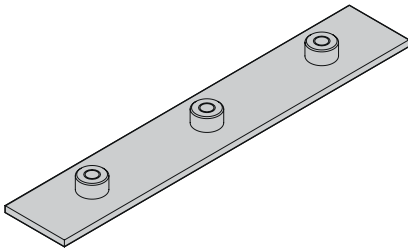

PIPE CLAMPS
MULTI SERIES

PSMC06 UPPER PLATE

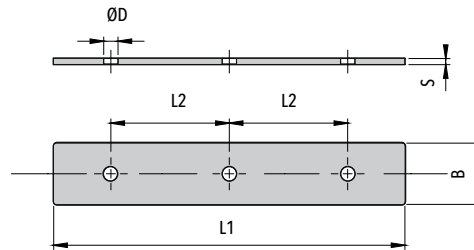

Code	L1	L2	B	S	ØD
------	----	----	---	---	----

PSMC06 A XPSMC06 A	116 (4.56")	40 (1.57")	30 (1.18")	3 (.12")	7 (.27")
-------------------------------------	----------------	---------------	---------------	-------------	-------------

PSMC06 B XPSMC06 B	172 (6.77")	58 (2.28")	30 (1.18")	3 (.12")	7 (.27")
-------------------------------------	----------------	---------------	---------------	-------------	-------------

PSMC06 C XPSMC06 C	214 (8.42")	72 (2.83")	30 (1.18")	3 (.12")	7 (.27")
-------------------------------------	----------------	---------------	---------------	-------------	-------------

Code **PSMC06** (Carbon Steel S 235 JR)
Code **XPSMC06** (Stainless Steel AISI 316L)

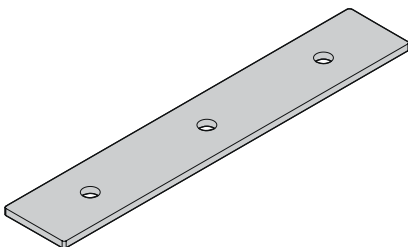

107



MC10 CLAMP BODY

FOR N. 10 PIPES

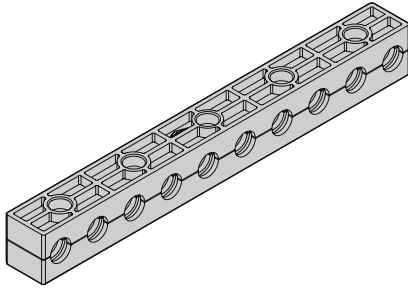

Code	Outside Diameter ØD		L1	L2	L3	B	H	S
	mm	nominal bore pipe in						
MC10 A	6							
	6,4	1/4"						
	8	5/16"	196 (7.71")	40 (1.57")	20 (.79")	30 (1.18")	28 (1.10")	0,6 (.02")
	9,5	3/8"						
	10	1/8"						
	12							
MC10 B	10	1/8"						
	12							
	12,7	1/2"						
	13,5	1/4"						
	14		288 (11.34")	58 (2.28")	29 (1.14")	30 (1.18")	34 (1.34")	0,6 (.02")
	15							
	16	5/8"						
	17,2	3/8"						
	18							
	15							
MC10 C	16	5/8"						
	17,2	3/8"						
	18							
	19	3/4"						
	20		358 (14.09")	72 (2.83")	36 (1.42")	30 (1.18")	38 (1.50")	0,8 (.03")
	21,3	1/2"						
	22	7/8"						
	23							
	25							
	25,4	1"						

PIPE CLAMPS
MULTI SERIES

108

Code MC10 (PP - PA - AU)

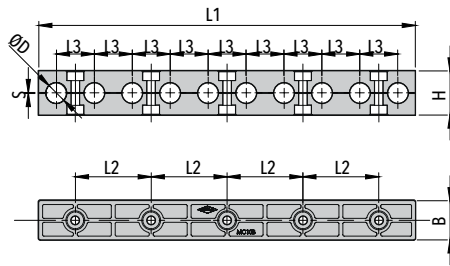

ORDER EXAMPLE

MC10 B - 15 - PP



PIPE CLAMPS MULTI SERIES

Order Codes and Dimensions (mm/in)

PMC10 WELD PLATE

WITH N. 5 SCREWS

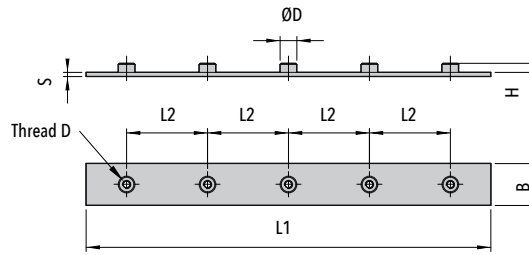

Code	Thread D	L1	L2	B	H	S	ØD
------	----------	----	----	---	---	---	----

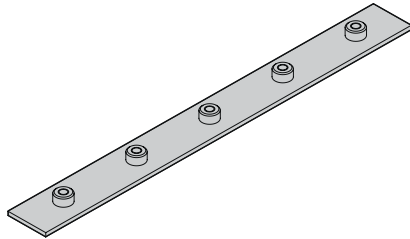

PMC10 A XPMC10 A	M6 (1/4-20 UNC)	198 (7.80")	40 (1.57")	30 (1.18")	6,5 (.25")	3 (.12")	12 (.47")
-----------------------------------	--------------------	----------------	---------------	---------------	---------------	-------------	--------------

PMC10 B XPMC10 B	M6 (1/4-20 UNC)	290 (11.41")	58 (2.28")	30 (1.18")	6,5 (.25")	3 (.12")	12 (.47")
-----------------------------------	--------------------	-----------------	---------------	---------------	---------------	-------------	--------------

PMC10 C XPMC10 C	M6 (1/4-20 UNC)	360 (14.17")	72 (2.83")	30 (1.18")	6,5 (.25")	3 (.12")	12 (.47")
-----------------------------------	--------------------	-----------------	---------------	---------------	---------------	-------------	--------------

Code **PMC10** (Carbon Steel S 235 JR)
Code **XPMC10** (Stainless Steel AISI 316L)

PIPE CLAMPS
MULTI SERIES

PSMC10 UPPER PLATE

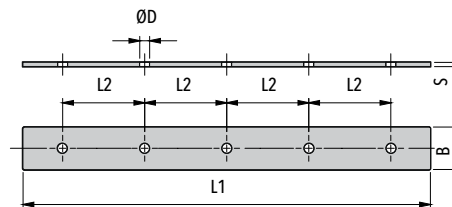

Code	L1	L2	B	S	ØD
------	----	----	---	---	----

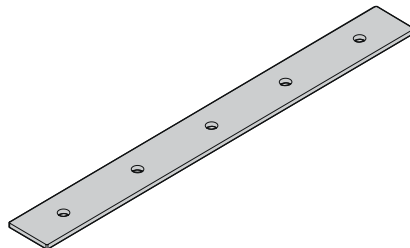

PSMC10 A XPSMC10 A	196 (7.71")	40 (1.57")	30 (1.18")	3 (.12")	7 (.27")
-------------------------------------	----------------	---------------	---------------	-------------	-------------

PSMC10 B XPSMC10 B	288 (11.33")	58 (2.28")	30 (1.18")	3 (.12")	7 (.27")
-------------------------------------	-----------------	---------------	---------------	-------------	-------------

PSMC10 C XPSMC10 C	358 (14.09")	72 (2.83")	30 (1.18")	3 (.12")	7 (.27")
-------------------------------------	-----------------	---------------	---------------	-------------	-------------

Code **PSMC10** (Carbon Steel S 235 JR)
Code **XPSMC10** (Stainless Steel AISI 316L)

109



VE HEXAGON HEAD BOLT

ISO 4014 / 4017
FOR USE WITH UPPER PLATE PS

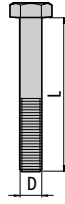

	Code	Thread (D x L)
FOR MCA	VE1-2 XVE1-2	M6x30 (1/4-20 UNCx1.1/4")
FOR MC B	VE3 XVE3	M6x35 (1/4-20 UNCx1.3/8")
FOR MC C	VE4 XVE4	M6x40 (1/4-20 UNCx1.1/2")

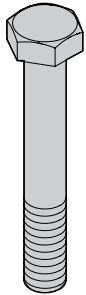

Code **VE** (Steel 8.8)
Code **XVE** (Stainless Steel A4)

TCEI SOCKET CAP SCREW

ISO 4762

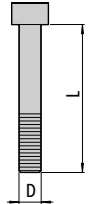

	Code	Thread (D x L)
FOR MCA	TCEI1-2 XTCEI1-2	M6x20 (1/4-20 UNCx3/4")
FOR MC B	TCEI3 XTCEI3	M6x25 (1/4-20 UNCx1")
FOR MC C	TCEI4 XTCEI4	M6x30 (1/4-20 UNCx1.1/8")

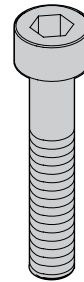

Code **TCEI** (Steel 8.8)
Code **XTCEI** (Stainless Steel AISI 316L)

110

RP FLAT WASHER

FOR USE WITH SCREW TCEI

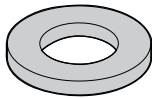
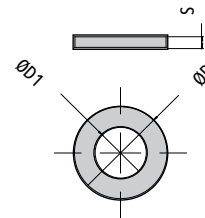

Code	ØD	ØD1	S
RP XRP	11,5 (.45")	6,3 (.25")	0,8 (.03")

Code **RP** (Carbon Steel S 235 JR)
Code **XRP** (Stainless Steel AISI 316L)



MOUNTING EXAMPLE 01

Mounting Example of complete clamp MC03-B in Polypropylene for pipe with outside diameter of 16 mm, with weld plate.

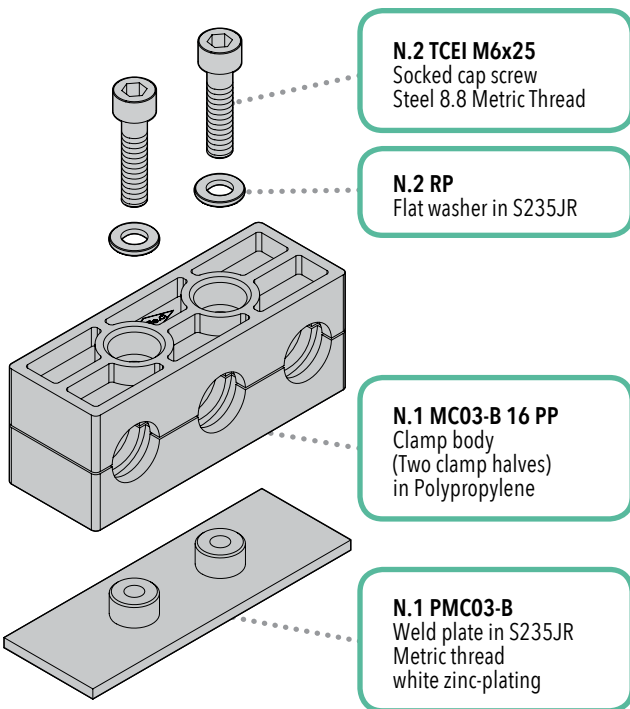

MOUNTING EXAMPLE 02

Mounting Example of complete clamp MC04-C in Polypropylene for pipe with outside diameter of 20 mm, mounting rail nut.

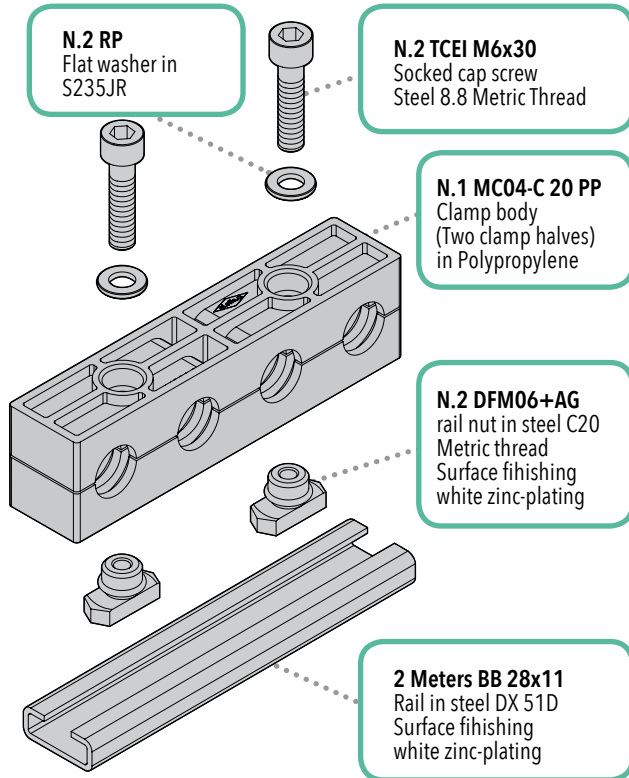

MOUNTING EXAMPLE 03

Mounting Example of complete clamp MC06-B in Polypropylene for pipe with outside diameter of 16 mm, with weld plate and upper plate.

