



KLIMOS

ARMATURA PRZEMYSŁOWA



Członek Polskiej Izby
Przemysłu Chemicznego

REF. 708

1 PIECE BALL VALVE PN40



- Size :** DN 1/4" to 2"
Ends : Threaded BSP
Min Temperature : -20°C
Max Temperature : + 180°C
Max Pressure : 40 Bars
Specifications : Anti blow-out stem
Locking device
1 piece type
- Materials :** Stainless steel

KLIMOS Piotr Chróścik
Ul. Waszyngtona 24 lok. 194
15-274 Białystok
NIP: 542-158-72-35

tel.: 85 742 01 82
tel. kom.: 602 12 50 12
e-mail: info@klimos.pl
www.klimos.pl

SPECIFICATIONS :

- Reduced bore
- Anti blow-out stem
- Locking device
- Solid ball
- 1 piece type

USE :

- Chemical and pharmaceutical industries, petrochemical industries, hydraulic installation, compressed air
- Min and max Temperature Ts : -20°C to + 180°C
- Max Pressure Ps : 40 bars (see graph)

PRESSURE / TEMPERATURE GRAPH (STEAM EXCLUDED) :

PRESSURE

BAR

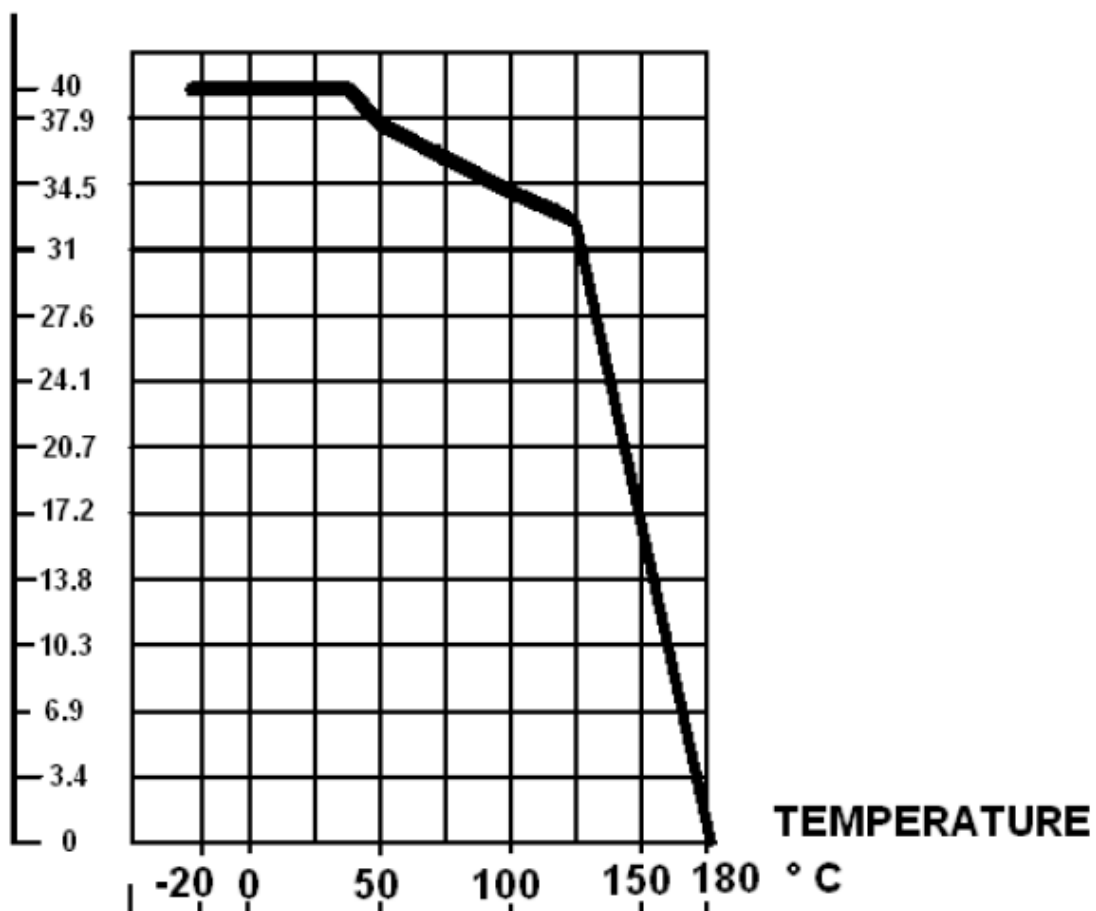

KLIMOS Piotr Chróścik
Ul. Waszyngtona 24 lok. 194
15-274 Białystok
NIP: 542-158-72-35

tel.: 85 742 01 82
tel. kom.: 602 12 50 12
e-mail: info@klimos.pl
www.klimos.pl

RANGE :

- Stainless steel DN 1/4" to DN 2"

ENDS :

- Female / female threaded BSP

MATERIALS :

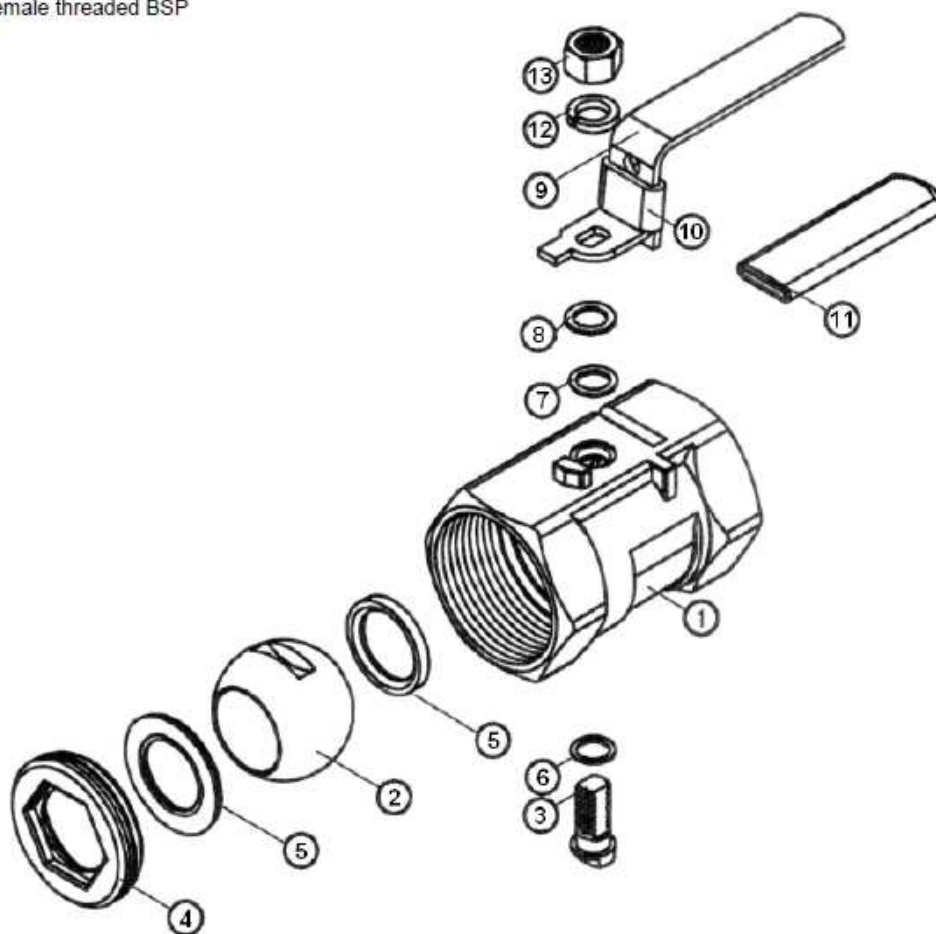

Item	Designation	Materials
1	Body	ASTM A351 CF8M
2	Ball	ASTM A351 CF8M
3	Stem	SS 316
4	Insert	SS 316
5	Seat	PTFE
6	Stem packing	PTFE
7	Thrust washer	PTFE
8	Gland	SS 304
9	Handle	SS 304
10	Locking device	SS 304
11	Handle cover	Plastic
12	Handle washer	SS 304
13	Handle nut	SS 304

KLIMOS Piotr Chróścik
Ul. Waszyngtona 24 lok. 194
15-274 Białystok
NIP: 542-158-72-35

tel.: 85 742 01 82
tel. kom.: 602 12 50 12
e-mail: info@klimos.pl
www.klimos.pl

SIZE (in mm) :

SIZE (in mm) :

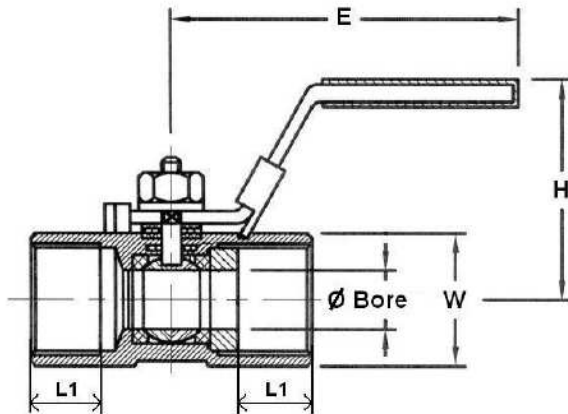
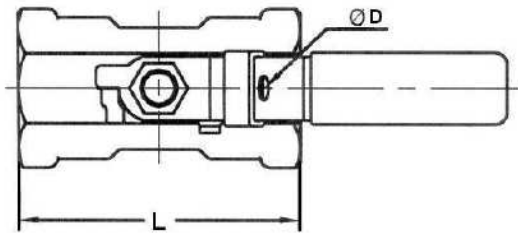

Stem size :

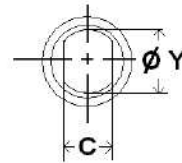

Ref.	DN	1/4"	3/8"	1/2"	3/4"	1"	1"1/4	1"1/2	2"
708	Ø Bore	5	6.8	9	12.5	16	20	25	32
	L	39	44	56.5	58.5	71	78	83	100
	Ø D	6	6	8	8	8	8	8	8
	E	62	62.5	96	96	101	101	135	135
	H	31	35.5	40	44	50	54	70	75
	L1	9.5	10.5	14	15	17	19	20	23
	W on flat	17	21	25	32	38	48	53	64
	C	3	4	5	5	6	6	8	8
	Ø Y	4,6	6	7	7	9	9	11.5	11.5
Weight (Kg)	0.06	0.1	0.19	0.26	0.41	0.62	0.84	1.33	

TORQUE VALUES (in Nm without safety coefficient) :

DN	1/4"	3/8"	1/2"	3/4"	1"	1"1/4	1"1/2	2"
TORQUE (Nm)	2	2	3	4	5	6	8	10

STANDARDS :

- Fabrication according to ISO 9001 : 2008
- DIRECTIVE 97/23/CE : CE N° 0035
Risk Category III Module H
- Pressure tests according to EN 12266-1, Range A
- Threaded cylindrical BSP ends according to ISO 228-1

KLIMOS Piotr Chróścik
Ul. Waszyngtona 24 lok. 194
15-274 Białystok
NIP: 542-158-72-35

tel.: 85 742 01 82
tel. kom.: 602 12 50 12
e-mail: info@klimos.pl
www.klimos.pl

INSTALLATION AND MAINTENANCE

BEFORE INSTALLATION :

Pipe-line must be cleaned and free from residual of weldings, rubbish, shaving and every kind of extraneous materials.
Pipe-line must be perfectly aligned and their support properly dimensioned so that there's no external constraint.

Please use the right product according to the services conditions to seal the valve.
Use the right bolt tightening so that the ends won't be damaged.

CLEANING AND TESTS

Keep closed the valves during the cleaning operation so that there's no impurities between the ball and the body.

Tests under pressure must be done with a cleaned pipe-line.

Open partially the valve for tests. Pressure test do not exceed the valve specifications according to EN 12266-1.

MAINTENANCE

It's recommended to operate the valve twice (open and close) 1 to 2 times per year.

When intervention on the valve, be sure there's no pressure in the pipe-line, there's no fluid in it, and that it is isolated.
The temperature must be low enough to operate without risks.
If there's a corrosive fluid, inert installation before intervention.

When the valve is under pressure :

If there's a leakage at the packing, tighten it slightly so that the leakage disappears.